



# ROBATHERM

Proudly Distributed By

**ROBAND®**

---

## Instruction Manual

COMMERCIAL MICROWAVE OVEN

---

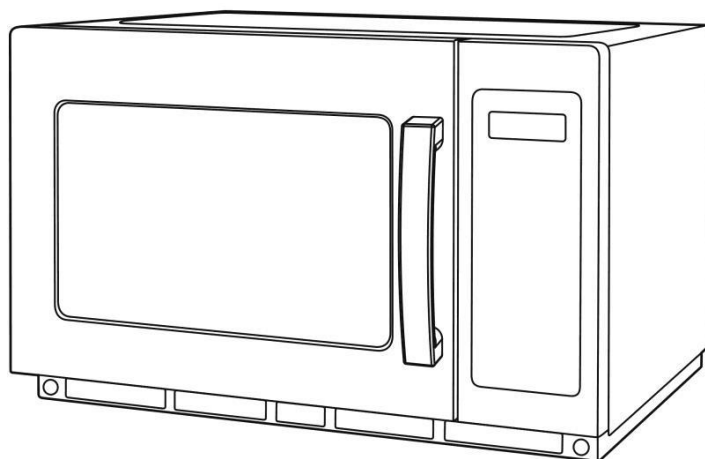

RM1834

Version 1

## CONTENTS

Product Features	2
Specifications*	2
Parts Included	2
General Safety Warnings	2
Operation Safety Warnings	3
Cleaning & Maintenance	3
Installation	4
Operation	5
Advanced user settings	7
Materials suitable for use	8
Troubleshooting	8

## PRODUCT FEATURES

- Commercial grade Stainless Steel exterior and interior.
- 34l internal capacity.
- Power level adjustable in 5 steps.
- 100 individually customizable cooking programs.
- Easy Clean interior surfaces.
- Dual Magnetrons.
- 15A Plug

## SPECIFICATIONS\*

Model	RM1834
Power Source	230 Volts AC ~ 50Hz
Input Power	3000 Watts
Output Power	1800 Watts
Oven Capacity	34 Liters
Oven Cavity (W x D x H)	360 x 409 x 225 mm
External Dimensions (W x D x H)	574 x 528 x 368 (includes handle and standoff)
Net Weight	32.2Kg
Packed Dimensions	641 x 559 x 451
Packed Weight	34.3Kg

\*Specifications subject to change

## PARTS INCLUDED

- Microwave Oven (appropriate model)
- Instruction Manual

## GENERAL SAFETY WARNINGS

Read all Instructions and safety warnings prior to use. Keep user manual for future reference.

Personnel must be trained prior to operating this appliance.

This product is suitable for commercial use only.

This machine should not be operated by persons with reduced physical, sensory or mental capabilities, or lack of experience or knowledge, unless they have been given supervision or instruction concerning the safe use of the appliance by a person responsible for their safety. Children should be supervised to ensure that they do not play with the appliance.

Avoid contact with the exterior of this machine as surfaces can get hot.

Do not cover or block filter or ventilation openings.

Keep power cord away from heated surfaces.

The machine should be disconnected from all power and allowed to cool before cleaning.

Regularly inspect the supply cord/plug and discontinue use immediately if damage is found.

This machine contains no user-serviceable parts. It is hazardous for anyone other than a competent person to carry out any service or repair operation that involves the removal of a cover which gives protection against exposure to microwave energy.

Touching internal electrical components may cause serious injury or death, even with the microwave unplugged. Do not remove cover unless qualified to do so.

This appliance must be returned to Roband Australia, or one of our agents to carry out repairs.

Do not remove any cover panels from the machine.

Roband will accept no liability if the instructions in this manual have not been followed.

## OPERATION SAFETY WARNINGS

If the door or door seals, door hinges or any part of the machine is damaged, the oven must not be operated until it has been repaired by an authorized person.

Do not operate oven without food or load in oven cavity.

Liquids and other foods must not be heated in sealed containers since they are liable to explode.

Microwave heating of beverages can result in delayed eruptive boiling, therefore care must be taken when handling the contents.

The contents of feeding bottles and baby food jars shall be stirred or shaken and the temperature checked before consumption, in order to avoid burns.

Only use utensils that are suitable for use in microwave ovens.

Do not put metal in the microwave oven.

When heating food in plastic or paper containers, keep an eye on the oven due to the possibility of ignition. If smoke is observed, switch off or unplug the appliance and keep the door closed in order to stifle any flames.

Eggs in their shell and whole hard-boiled eggs should not be heated in microwave ovens since they may explode, even after microwave heating has ended.

The oven should be cleaned regularly and any food deposits should be removed. Failure to maintain the oven in a clean condition could lead to deterioration of the surface that could adversely affect the life of the appliance and possibly result in a hazardous situation.

### **Ceramic Glass oven cavity base**

The special Ceramic Glass oven cavity base used in the ROBAND® Microwave ovens has a high impact strength however impact from sharp objects or heavy blows to the edges can lead to breakage.

## CLEANING & MAINTENANCE

**CAUTION:** Disconnect from power and allow to cool before cleaning.

**CAUTION:** Steel cutting processes used in the construction of this machine can result in sharp edges. Avoid contact with sharp edges during cleaning and maintenance.

**CAUTION:** Do not wipe plastic and painted sections of the oven with bleach, thinners or other cleaning agents, as this may cause these parts to dissolve or change shape.

Toxic cleaners should be avoided when cleaning the inside of the Microwave as they may contact food.

Caustic cleaners should always be avoided, as they may damage components inside and outside the unit.

This unit is not suitable for cleaning with the use of a water jet or immersion.

The door frame, seal and parts nearby must be cleaned carefully with a damp cloth when they are dirty.

Do not use harsh abrasive cleaners or sharp metal scrapers to clean the oven door components since they can scratch the surface, causing damage to the door or shielding mesh within.

If the supply cord is damaged it must be replaced by a cord set supplied by Roband. Internal maintenance should only be performed by a Roband or one of our service agents in order to avoid a hazard.

### **Cleaning the control panel:**

Do not use detergent or an alkaline spray to clean the control panel as this may cause damage. Use a dry or a cloth lightly dampened with water to clean.

### **Cleaning the Microwave interior:**

After use, clean up any spilled liquids, spattered oil and food as quickly as possible. If the oven is used while dirty the efficiency drops and the food may get stuck on the interior. Clean the interior with a cloth soaked in warm water with mild detergent dissolved in it, and then rinse the residue off with a damp cloth.

Regular cleaning will prevent a build-up of oils and foodstuff and keep the machine looking new.

### Filter Cleaning:

It is important to clean the air filter regularly to avoid clogging and overheating the microwave. To clean the air filter, unfasten the mounting screws (arrowed below) and remove filter. Wash with warm soapy water until unclogged, dry off then reinstall and fasten the screws.

**NOTE:** A Clean filter reminder will display every 30 days. This can be shut off by pressing and holding the 'Stop' button for 5 seconds while in idle mode.

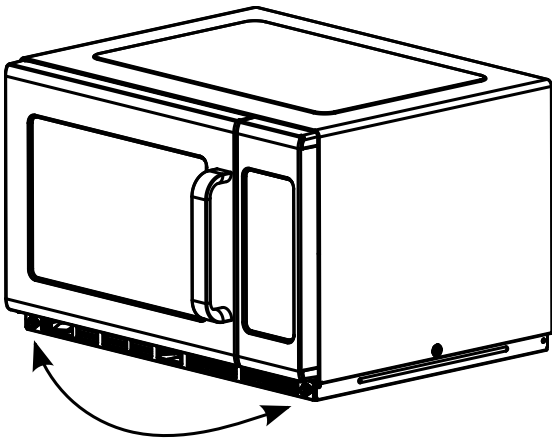

### Splash Shield Cleaning:

The Splash Shield at the top of the oven interior should be regularly cleaned using a cloth soaked in warm soapy water. Do not use cleaning chemicals or sanitiser.

In cases of extreme contamination, the Splash Shield can be removed for cleaning as follows:

1. Firmly lever the left and right locking tabs towards the rear of the oven, as shown by the arrows below, and then lower the front of the Splash Shield and withdraw from oven, **taking care not to damage the stirrer fan in the oven ceiling.**
2. Wash shield in warm soapy water. Do not place in dishwasher. Do not use cleaning chemicals or sanitiser.
3. After washing, dry off the Splash Shield and reinsert by positioning the three location pins into their location holes in the rear panel, **taking care not to damage the stirrer fan in the oven ceiling.** Then raise the front of shield while pressing the locking tabs rearward until it clips lock back into the front retainer.

**CAUTION:** Ensure the Splash Shield is installed correctly before operating microwave.

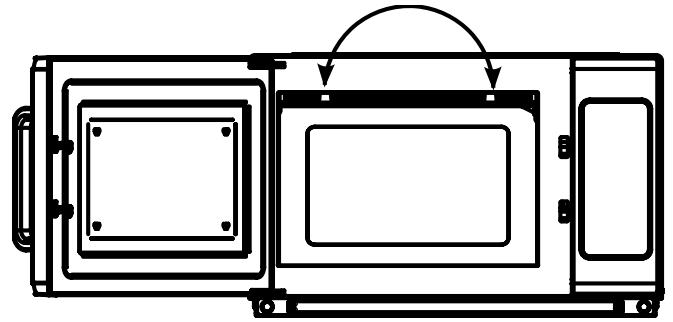

## INSTALLATION

**IMPORTANT:** DO NOT USE THE MICROWAVE DOOR HANDLE TO LIFT THE MICROWAVE OVEN.

Any damage to the machine as a result of freight must be reported to the Freight Company and to the agent responsible for the dispatch of machine within 24 hours of receipt. No claims will be accepted after this period.

**Do not under any circumstances attempt to use a damaged product.**

Remove all packaging materials, tape, and any protective plastic from the machine. Remove any glue residue from the protective plastic or tape using citrus cleaner.

Product should be installed at counter height only (approximately 800- 1100mm). Installing outside the recommended mounting height could cause damage to the door hinges and prevent operation.

Do not position the microwave on top of or immediately above another appliance.

Place the product on a firm, level surface in the desired position.

Maintain a clearance of 300mm above the microwave, note a second microwave of the same model can be stacked on top as long as a 300mm clearance can be maintained above the second microwave.

Allow at least 100mm clearance from back and sides when positioning the microwave.

Do not obstruct filter or ventilation openings. Install away from TV and radio sets as reception and radio interference might be affected.

Do not position Microwave near sources of heat, water, oil or steam.

Do not stack any appliances or materials on the top of the microwave.

Do not connect to power using a power board or extension cord.

**WARNING:** This product must be connected to an RCD protected circuit, ensure the circuit is properly earthed.

Before connecting the machine to the power supply, ensure that all switches are in the OFF position. Connect only to an RCD protected, grounded 15A 3-pin outlet.

**Stacked installation:** Where 2 microwaves are to be stacked on top of each other, use the mounting plate on the back of each machine by unscrewing them and screwing the machines together as detailed below.

1. Unscrew and remove the mounting plates, and then replace and tighten the screws at "A".
2. Remove the four screws as shown at "B".
3. Use the 4 screws to fasten the 2 mounting plates at "B" on each side of the machine.

**NOTE:** never stack more than two microwaves on top of each other.

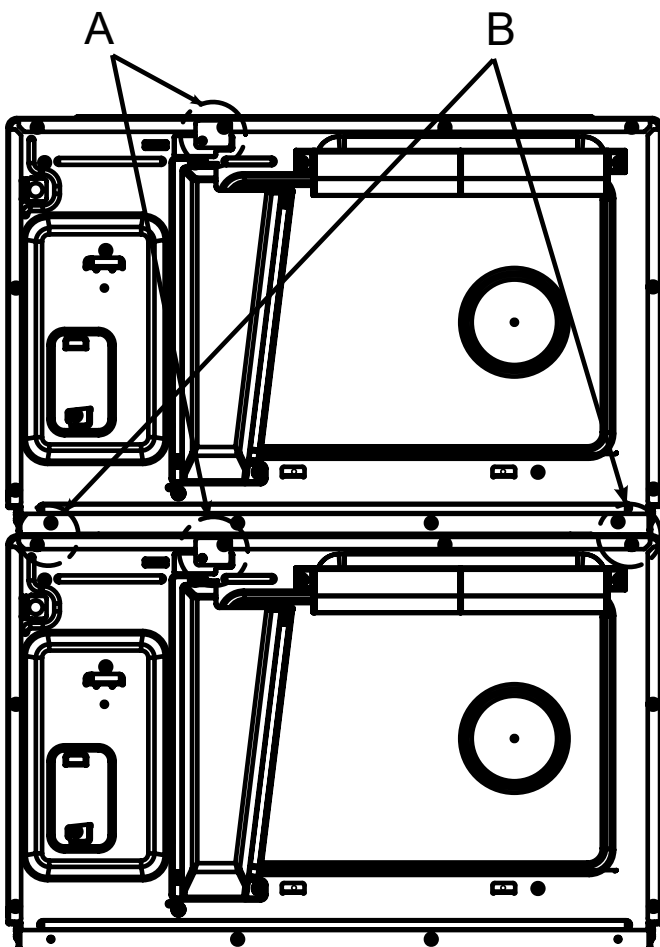

## OPERATION

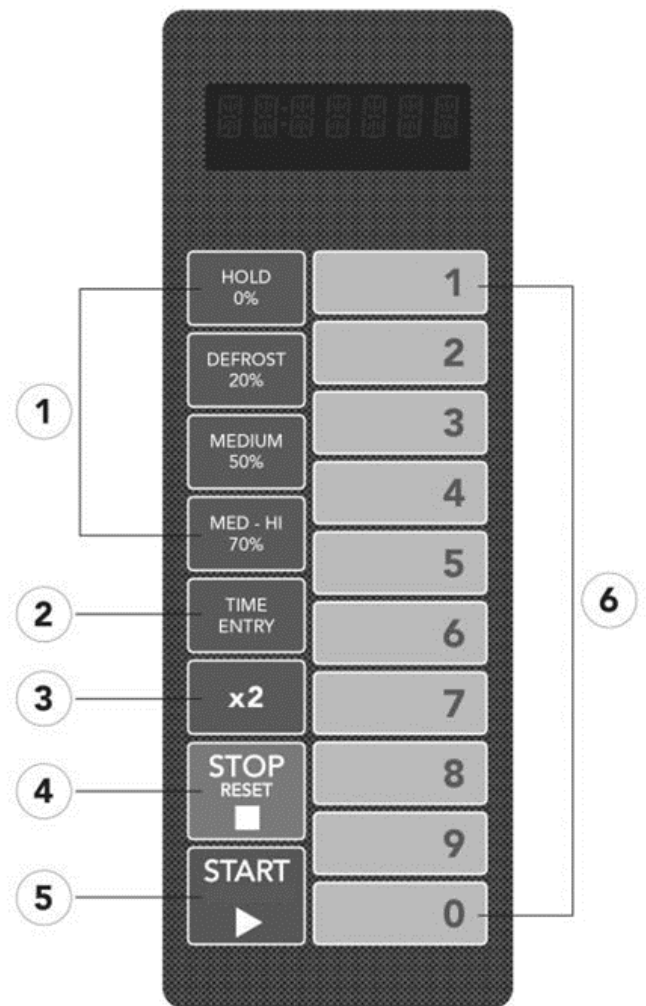

1. **POWER LEVEL** – Used to select power.
2. **TIME ENTRY** – To enter cooking time.
3. **x2** – Double quantity.
4. **STOP / RESET** – To stop Cooking and Reset timer.
5. **START** – Begin/resume cooking.
6. **NUMERAL PAD 0-9** – To input time or program.

### NORMAL COOKING - MANUAL OPERATION

1. Place the food to be cooked or heated in a container suitable for use in a microwave then place inside the oven and close the door. "READY" will be displayed.
2. Set cooking time by pressing 'TIME ENTRY' then enter cooking time using the 'NUMERAL' keypad.

3. Select desired power by pressing '**HOLD - 0%**', '**DEFROST – 20%**', '**MEDIUM - 50%**' or '**MED -HI - 70%**'.

**NOTE:** The microwave will operate at 100% power if no power level is selected.

4. Press '**START**' to begin cooking.

**NOTE:** For 100% power no power setting is displayed. If other power levels have been selected it can be deactivated by pressing the button again.

5. Cooking can be paused by pressing '**STOP**' once or by opening the door. To resume cooking while paused close the door if open and or press '**START**'. Pressing '**STOP**' while paused or with the door open will clear the remaining time.

**NOTE:** The oven can be programmed for a maximum of 60 minutes.

**NOTE:** Using a low power may increase cooking time, but may produce a more uniform result in foods such as dairy and meats.

The cooling fan will run to prevent microwave components from overheating.

### STAGED COOKING

The microwave can cook in sequences of up to 3 Time / Power settings which run sequentially without further input from the user. The display will show the total time while cooking.

#### Stage 1:

1. Place the food to be cooked or heated in a container suitable for use in a microwave then place inside the oven and close the door. "**READY**" will be displayed.
2. Set cooking time by pressing '**TIME ENTRY**' then enter cooking time using the '**NUMERAL**' keypad.
3. Select desired power by pressing '**Hold-0%**', '**DEFROST – 20%**', '**MEDIUM - 50%**' or '**MED - HI - 70%**' (skip this step for 100% power).

#### Stage 2 & 3:

4. Press '**TIME ENTRY**' again and "**STAGE-2**" is displayed. Enter desired cooking time for Stage 2 using the '**NUMERAL**' keypad.
5. Select desired power by pressing '**HOLD - 0%**', '**DEFROST – 20%**', '**MEDIUM - 50%**' or '**MED - HI - 70%**' (skip this step for 100% power).

**Repeat Steps 4) and 5) if Stage 3 is required.**

6. Press '**START**' to begin cooking or '**STOP**' to cancel programming.

When a staged program is run the microwave will run through each stage automatically without user input. The display will show total time for all stages.

7. Cooking can be paused by pressing '**STOP**' once or by opening the door. To resume cooking while paused close the door if open and or press '**START**'. Pressing '**STOP**' while paused or with the door open will clear the remaining time.

### DEFROST

Defrost function cycles power intermittently to assist food to thaw evenly.

1. Place the food to be defrosted in a container suitable for use in a microwave then place inside the oven and close the door. "**Ready**" will be displayed.
2. Press the '**TIME ENTRY**' button and enter desired time using the '**NUMERAL**' key pad.
3. Press '**DEFROST**'.
4. Press '**START**' to begin defrosting.

**NOTE:** The maximum defrost time is 60 minutes.

### PROGRAMED MENU

The microwave can store up to 10 Pre-Programmed Time / Power sequences. This can be increased to 100 Programs under "Advanced User Settings."

To select a pre-programmed sequence;

1. Place the food to be cooked or heated in a container suitable for use in a microwave then place inside the oven and close the door. "**READY**" will be displayed.
2. Enter the '**NUMBER**' for the desired program '**0-9**', OR select '**00-99**' when 100 programs is enabled.

The oven will then automatically begin the programmed cook sequence after a short pause.

3. Cooking can be paused by pressing '**STOP**' once or by opening the door. To resume cooking while paused close the door if open and or press '**START**'. Pressing '**STOP**' while paused or with the door open will clear the remaining time.

Number	Cooking Time	Power Level
1	0:10	100%
2	0:20	100%
3	0:30	100%
4	0:45	100%
5	1:00	100%
6	1:30	100%
7	2:00	100%
8	2:30	100%
9	3:00	100%
0	3:30	100%

### Pre-Programmed Cooking Times and Power Level:

Note: the above programmed times and power levels can all be changed if desired.

### PROGRAMMED MENU SETUP

1. Open the door.
2. Press and Hold **'1'** for 5 seconds. The display will read **"PROGRAM"**.
3. Enter the Program number to be changed - **'0-9'**, OR **'00-99'** when 100 programs is enabled.
4. The current cooking time is displayed, use the **'NUMERAL'** keypad to enter a new time.
5. Set new Power level by pressing **'HOLD - 0%'**, **'DEFROST - 20%'**, **'MEDIUM - 50%'** or **'MED-Hi - 70%'** (skip this step for 100% power).

### STAGED COOKING

Staged cooking sequences can also be saved to the programmed menu. A staged program will cook in 2-3 sequential Time/Power stages.

6. If **Staged cooking** is required, press **'TIME ENTRY'** the display will show **'STAGE-2'** then repeat steps 4 and 5. Repeat for up to 3 stages.
7. Press **'START'** to save or **'STOP'** to cancel.

When a staged program is run the microwave will run through each stage automatically without user input. The display will show total time for all stages.

### DOUBLE QUANTITY COOKING

The cooking times of programmed menus can be adjusted for double the food quantity by pressing **'x2'**, then pressing the desired programmed menu number within 5 seconds. Alternatively select the desired program the press **'x2'**.

**NOTE:** The time will increase by 1.8 times the programmed time to account for the additional food load.

### ON THE FLY COOKING

When cooking with a 'Programed menu', any other 'Pre-Programmed Menu' can be run on the fly by pressing the corresponding program number. In this situation, the remaining time and power will be updated to that of the new Pre-Programmed menu.

### ADVANCED USER SETTINGS

User options can be changed to customize the machine.

1. Open the oven door.
1. Press hold button **'2'** for 5 seconds. **"OP:--"** is displayed.
2. Press the first digit of the setting you want to modify (ref table below).
3. Press the first digit again to cycle through the available options. For example: To set the buzzer volume to medium. Press **'2'**, **"OP:22"** is displayed. Each subsequent press of the number **'2'** will cycle through the options **"OP:21"**, **"OP:22"**, **"OP:23"**, **"OP:20"**.
4. Press **'START'** to save the desired setting or **'STOP'** to exit without saving.
5. After modifying desired settings, press **'STOP'** and close the door.

Option	Setting	Description
1 Buzzer Tone	<b>OP:10</b>	<b>3 seconds beep</b>
	OP:11	Continuous beep
	OP:12	5 quick beeps, repeating
2 Buzzer Volume	OP:20	Beeper Off
	OP:21	Low
	<b>OP:22</b>	<b>Medium</b>
	OP:23	High
3 Buzzer On/Off	OP:30	Keypad beep Off
	<b>OP:31</b>	<b>Keypad beep On</b>
4 Keyboard Window	OP:40	15 seconds
	OP:41	30 seconds
	<b>OP:42</b>	<b>60 seconds</b>
	OP:43	120 seconds
5 On the Fly	OP:50	On-the-Fly Disabled
	<b>OP:51</b>	<b>On-the-Fly Enabled</b>
6 Door Reset	<b>OP:60</b>	<b>Door reset Disabled</b>
	OP:61	Door Reset Enabled
7 Max time	<b>OP:70</b>	<b>60 Minute Maximum Cook Time</b>
	OP:71	10 Minute Maximum Cook Time
8 Manual Programmi ng	OP:80	Manual Programming Disabled
	<b>OP:81</b>	<b>Manual Programming Enabled</b>
9 Double Digit	<b>OP:90</b>	<b>Single Digit Mode-10 programs</b>
	OP:91	Double Digit Mode-100 programs

**Note:** Settings in bold are default settings

### RESTORE FACTORY DEFAULTS

Follow the steps below to return the unit to factory default settings.

**NOTE:** All programmable menus will be restored to default by this procedure.

1. Open and close door.
2. Press and hold '**START**' and '**0**' together until display shows "**00**" then release.

3. Press '**START**', the display will show "**CLEAR**" then "**CHECK**" then "**11**" the oven is now reset.

### MATERIALS SUITABLE FOR USE

- Items containing metal should not be used in the microwave as they may cause sparking. Even a small amount of metal plating on the edge of dishes and cups can cause sparking and should not be used.
- Combustible materials such as paper should be used with caution as they may ignite. Use only for short cooking times and only while attended.
- Plastic foam should not be used in the microwave as it may melt and contaminate food.
- Use only products marked as microwave safe for ceramic, glass and plastic products.

### TROUBLESHOOTING

Only after all points below have been checked should you call for service:

#### If the Microwave is not working:

- ✓ Check that the machine is plugged into the power point correctly and the power is switched on and working.
- ✓ Check that the door is properly closed and not obstructed by food or any object.

#### If the Microwave is sparking in the cavity:

- ✓ Check that there are no metal utensils, metal containers or dishes with metal trim being used.



## NOTES

This page is intentionally left blank

# NOTES

This page is intentionally left blank

## NOTES

This page is intentionally left blank

# WARRANTY

The warranty conditions set out below are in addition to any warranties implied or governed by law.

Roband Australia warrants that this appliance shall be delivered free from defects in material and workmanship. The warranty for this product is offered to the original purchaser, to be free of fault in both workmanship and materials for a period of 12 months from date of purchase. Roband's obligations pursuant to this warranty are limited to the repair or replacement of the defective goods or materials, at its discretion and subject to the terms contained within this Warranty statement.

## ***The following conditions apply:***

The product must be installed, maintained and used under normal operating conditions within the scope of the operating instructions.

All warranty claims must be submitted to Roband or an authorised Roband dealer, and Roband authorisation must be granted prior to repairs being carried out. Proof of purchase is required for any repair authorisation.

Warranty is back to base, meaning delivery to and collection of your product to Roband or an authorized service agent is the responsibility of the purchaser.

## ***The following exclusions apply:***

Claims or faults arising from misuse, neglect, transport damage or other mechanical damage, including but not limited to; doors, hinges & interlock switches etc., other than those arising from manufacture or material defects.

Roband or any subsidiary company or Agent shall not be liable for loss of profit or damage to other equipment and property except where it is in breach of the guarantees provided in accordance with applicable legislation.

Roband reserves the right to reject a warranty claim if it is not satisfied with the circumstances under which the fault occurred or where a product has been altered from its original specification.

Any costs incurred for false claims or faults due to incorrect usage etc. are the responsibility of the claimant.

Any attempt to repair the product by non-Roband approved service personnel or the use of non-genuine parts will void the warranty agreement.

Our goods come with guarantees that cannot be excluded under the Australian Consumer Law. You are entitled to a replacement or refund for a major failure and compensation for any other reasonably foreseeable loss or damage. You are also entitled to have the goods repaired or replaced if the goods fail to be of acceptable quality and the failure does not amount to a major failure.

## ***Extended Warranty***

Extended 12 months parts only warranty is offered for Heavy Duty dual magnetron machines making the total warranty period 24 months parts & 12 months labour (Subject to conditions and exclusions above)

Authorised service agents are located in most areas which have authorised distribution dealers.

For the name of your nearest Australian authorised service agent, please contact:

### **Roband Australia Pty Ltd**

1 Inman Road,  
Cromer, NSW, 2099, Australia,  
Warranty: 1800 268 848  
Tel: +61 2 9971 1788  
Email: [sales@roband.com.au](mailto:sales@roband.com.au)  
Web: [www.roband.com.au](http://www.roband.com.au)

### **For your nearest international distributor, please visit:**

<https://www.roband.com.au/global/>

### **© Copyright 2021 – Roband® Australia Pty Ltd**

All rights reserved. No part of this work may be reproduced or copied in any form or by any means, electronic or mechanical, including photocopying or posting to a website, without the written permission of the publisher. The material contained within this document is intended entirely for instructional Purposes. Roband® Australia is a wholly Australian owned company and has been manufacturing quality commercial catering equipment for the food service industry for more than 60 years.