

Instruction Manual

Heat 'N' Hold Trolley

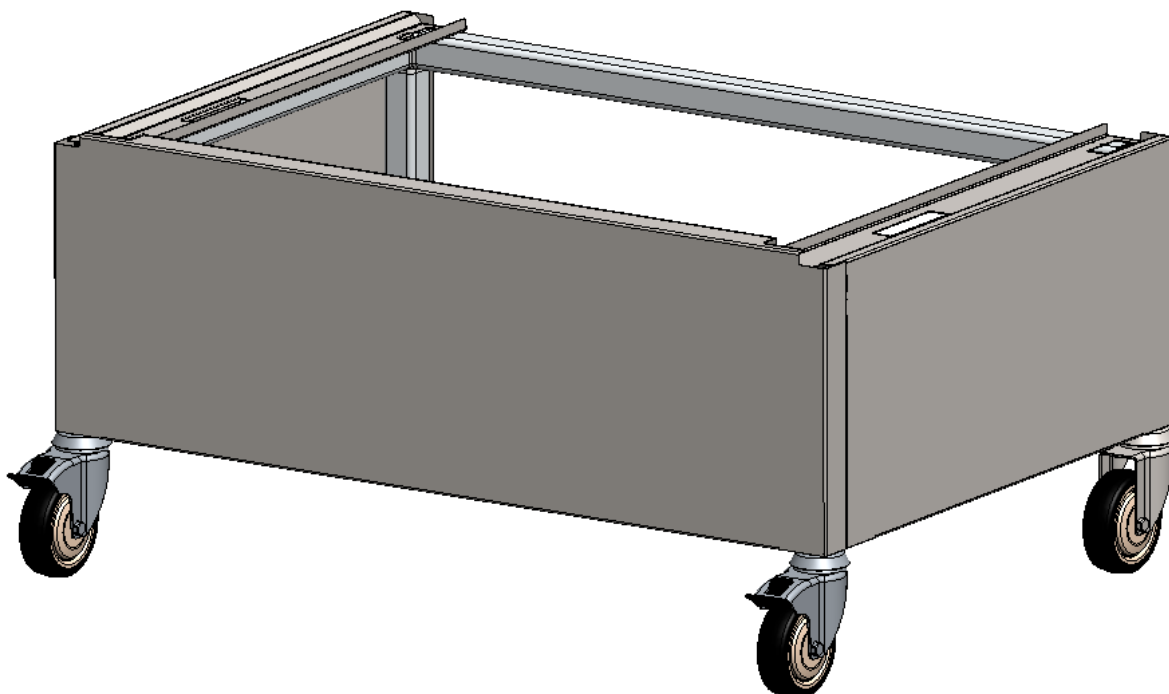

HT200

version 1

CONTENTS

ITEM NO.	PART NO.	DESCRIPTION	QTY
A	DC0103	JOINER	4
B	DC0104	JOINER COVER	4
C	MC0761	SCREW	4
D	MS0416	CASTER BOX SET	1
E	MS0589	HORIZONTAL FRAME	4
F	MS0590	VERTICAL FRAME	4
G	MS0591	SIDE FRAME	4
H	PC0326	PLUG	8
I	SS3329	FRONT PANEL	1
J	SS3330	LHS PANEL	1
K	SS3331	RHS PANEL	1
L	SS3333	SHELF	2

Tools required: 5mm allen key (supplied in castor box), rubber mallet.

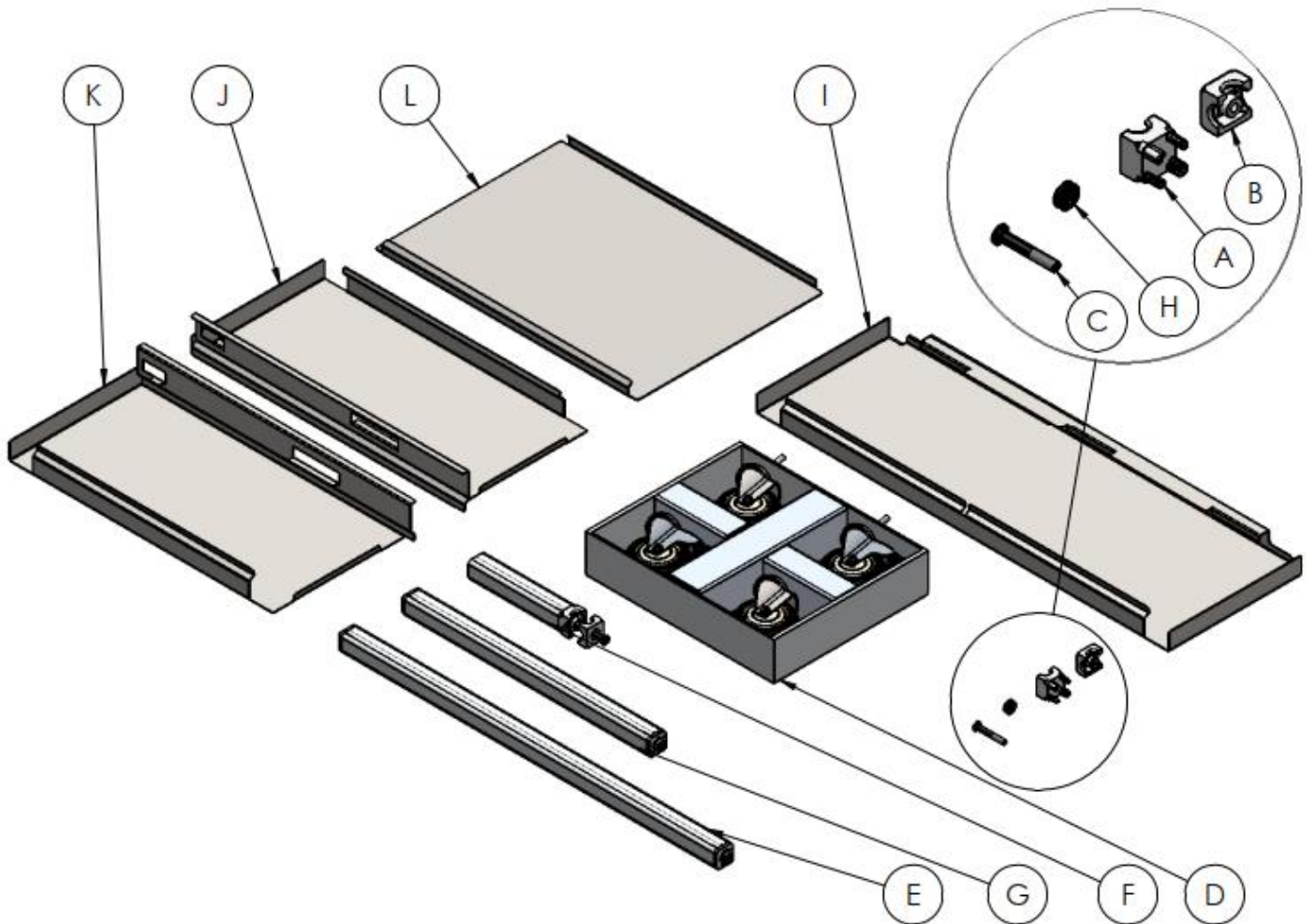

Instructions

1. Organise the trolley frame as pictured taking note of the different frame pieces.
2. Seat frames **E** & **G** inside frame **F** as well as the plug (**H**) in the free hole.
Note, frame **F** comes pre-assembled with the joiner and joiner cover (**A** & **B**) and will need to be unscrewed before placing the frames inside.
3. After the frames and plug have been seated, place the joiner cover (**B**) over and fasten with screw (**C**) using the supplied allen key. Note, the mallet may be required to close the cover sufficiently to fasten.

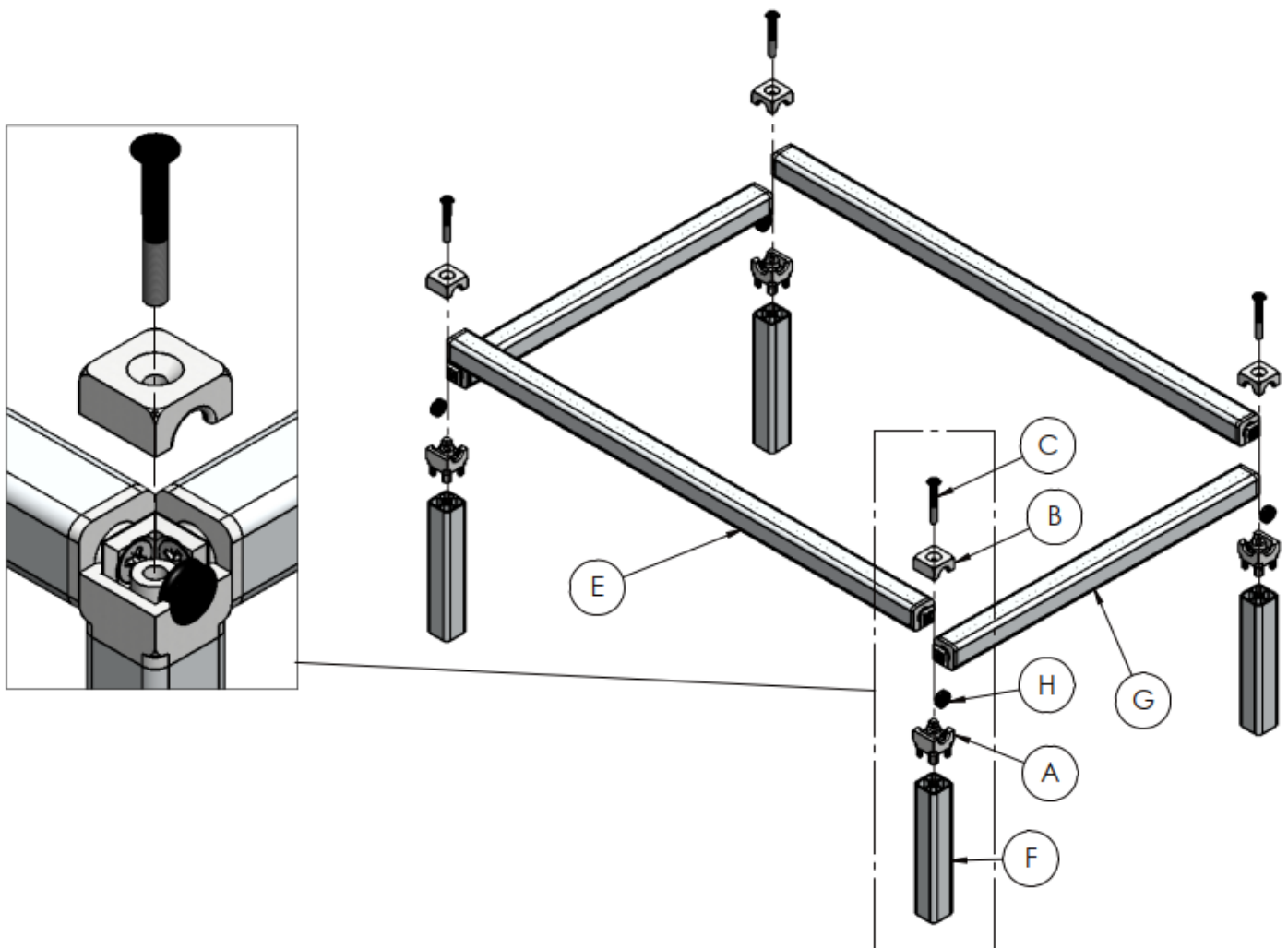

4. Flip the trolley.
5. Place joiner cover (A) inside frame (F).
6. Seat frames E & G inside joiner cover (A) as well as the plug (H) in the free hole.
7. After the frames and plug have been seated, place the joiner cover (B) over and fasten with screw supplied with the castors (D) taking note of the castor break* location as pictured. Note, the mallet may be required to close the cover sufficiently to fasten.

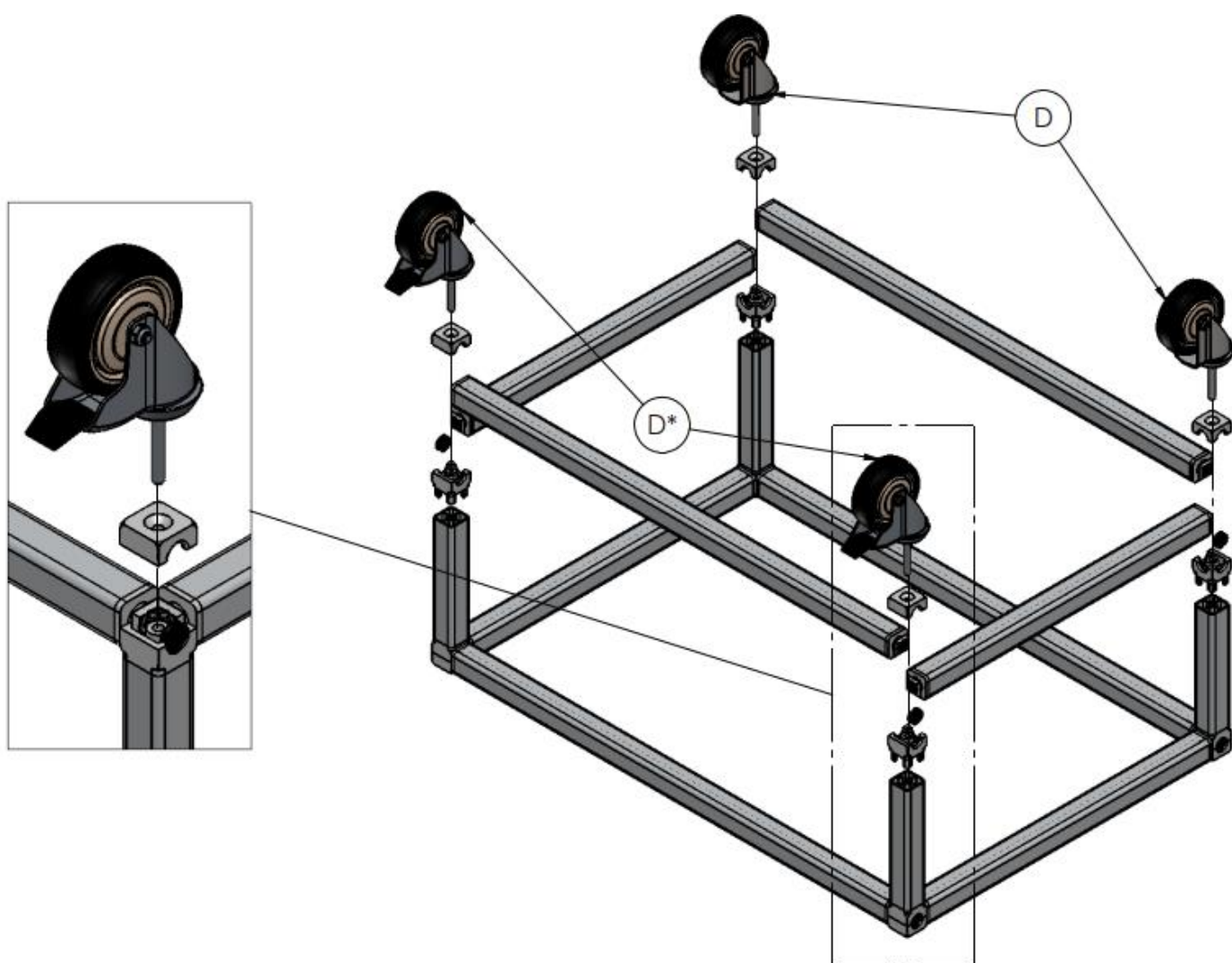

8. Using the side panels (J & K), hook the panel over the top of the side frame (G). While pushing down on the top, push the bottom of the frame so that it snaps over the bottom side frame. The side panels should now sit flush with the trolley frame.
9. Repeat the above step using the front panel (I).
10. Place the shelves (L) on the bottom of frame.

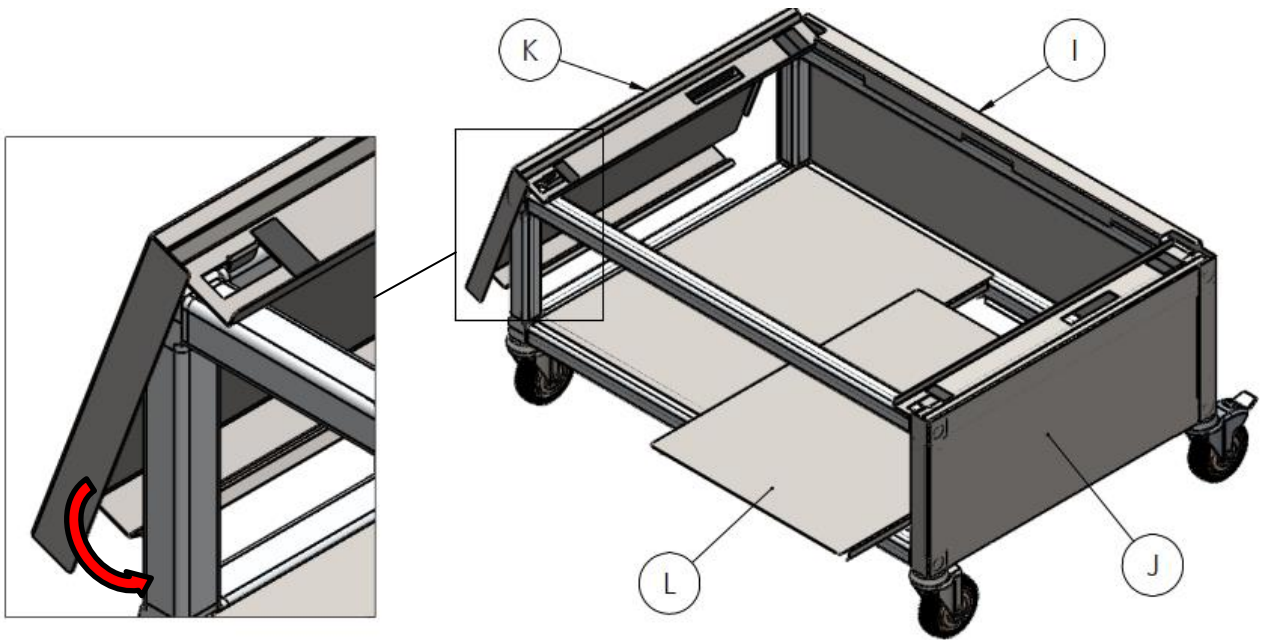

11. Place the H200 unit onto the trolley ensuring that the non-control side of the H200 is facing the front panel of the trolley. Note, the feet should sit on top of the rubber strips.

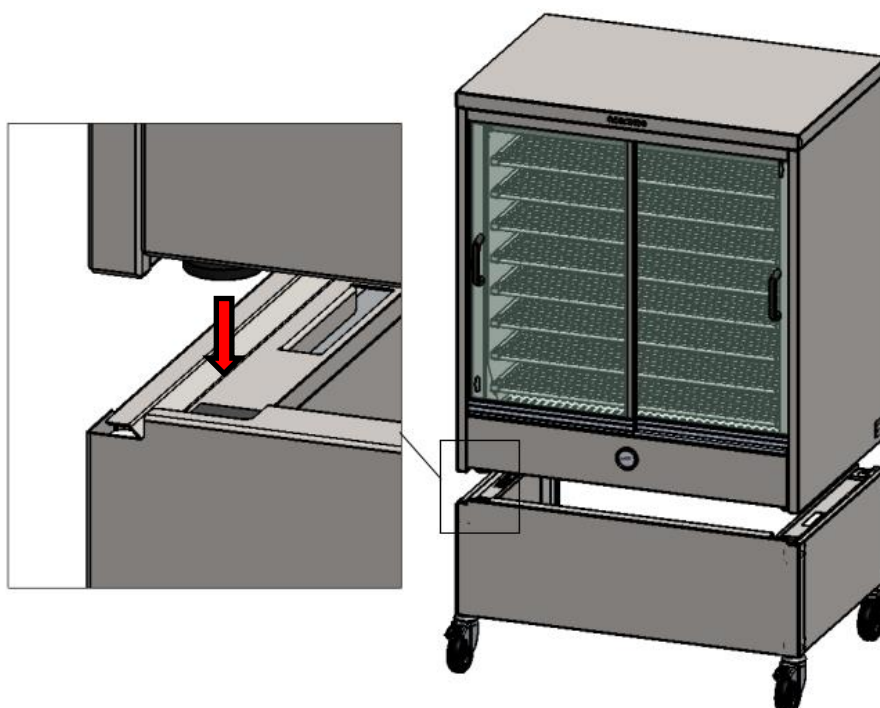

NOTES

WARRANTY

The warranty conditions set out below are in addition to any warranties implied or governed by law.

Roband Australia warrants that this appliance shall be delivered free from defects in material and workmanship. The warranty for this product is offered to the original purchaser, to be free of fault in both workmanship and materials for a period of 12 months from date of purchase. Roband's obligations pursuant to this warranty are limited to the repair or replacement of the defective goods or materials, at its discretion and subject to the terms contained within this Warranty statement.

The following conditions apply:

The product must be installed, maintained and used under normal operating conditions within the scope of the operating instructions.

All warranty claims must be submitted to Roband or an authorised Roband dealer, and Roband authorisation must be granted prior to repairs being carried out. Proof of purchase is required for any repair authorisation.

Warranty is back to base, meaning delivery to and collection of your product to Roband or an authorized service agent is the responsibility of the purchaser.

Where a product cannot be returned back to base, on-site warranty can be arranged by prior agreement.

The following exclusions apply:

Claims or faults arising from misuse, neglect, transport damage or other mechanical damage, including but not limited to; door's, hinges & interlock switches etc., other than those arising from manufacture or material defects. Where relevant, glass, Teflon® and lamps are not included in this warranty and RCD tripping due to moisture absorption by Tubular Heating Elements is not a warranty fault.

Roband or any subsidiary company or Agent shall not be liable for loss of profit or damage to other equipment and property except where it is in breach of the guarantees provided in accordance with applicable legislation.

Roband reserves the right to reject a warranty claim if it is not satisfied with the circumstances under which the fault occurred or where a product has been altered from its original specification.

For on-site repairs outside of capital city metropolitan areas, travel costs, service callout fee and related labour costs etc. are the responsibility of the claimant.

Any costs incurred for false claims or faults due to incorrect usage etc. are the responsibility of the claimant.

Any attempt to repair the product by non-Roband approved service personnel or the use of non-genuine parts will void the warranty agreement

Our goods come with guarantees that cannot be excluded under the Australian Consumer Law. You are entitled to a replacement or refund for a major failure and compensation for any other reasonably foreseeable loss or damage. You are also entitled to have the goods repaired or replaced if the goods fail to be of acceptable quality and the failure does not amount to a major failure.

For the name of your nearest Australian authorised service agent, please contact:

Roband Australia Pty Ltd
1 Inman Road,
Cromer, NSW, 2099, Australia
Warranty: 1800 268 848
Tel: +61 2 9971 1788
Email: sales@roband.com.au
Web: www.roband.com.au

For your nearest International distributor,
please visit:
<https://www.roband.com.au/worldwide/>



© Copyright 2021 – Roband® Australia Pty Ltd

All rights reserved. No part of this work may be reproduced or copied in any form or by any means, electronic or mechanical, including photocopying or posting to a website, without the written permission of the publisher. The material contained within this document is intended entirely for instructional Purposes. Roband® Australia is a wholly Australian owned company and has been manufacturing quality commercial catering equipment for the food service industry for more than 60 years.