



Manufactured By
ROBAND AUSTRALIA PTY LTD



OPERATING INSTRUCTIONS

BAIN MARIE

Models:

BM1 Version 3, BM21 Version 2

BM2, BM4 Version 5

Includes

International models: ...-Gxx
...-Fxx
...-Mxx
Alternate Plate Models: ...-T

Special Features:

- Slim Line Thermometer
- Ultra-Durable Stainless Steel Elements
- On/Off Switch that Electrically Isolates the Unit from Mains Power



These instructions cover the models of ROBAND® Bain Maries listed above. Although there are slight variances between models, the installation, operation, care and maintenance procedure is the same for all.

Roband® Australia is a wholly Australian owned company and has been manufacturing quality commercial catering equipment for the food service industry for more than 50 years. Roband products are engineered and manufactured to the highest standards to provide functionality, reliability and durability, and our quality products are exported world-wide.

Included in the comprehensive Roband® range are Toasters, Fryers, Milkshake Mixers, Rotisseries, Food Display Cabinets and much more.

Roband® Australia also acts as the Australian agents for Vitamix® Blenders, Noaw® Meat Slicers, Förje® Cookware, Robalec™ Soup/Rice Warmers, Robatherm Urns, Austheat® Fryers, Dipo Induction & Autofry Machines. Roband also has its own line of commercial cookware and cutlery under the Robinox® brand name.

For a complete set of brochures please contact your nearest authorised dealer or contact Roband directly at our head office.

Roband Head Office Sydney, Australia	
Roband Australia Pty Ltd 1 Inman Road Dee Why NSW 2099 AUSTRALIA	Tel: +61 2 9971 1788 Fax: +61 2 9971 1336 Email: sales@roband.com.au Web: www.roband.com.au
International Agents For additional agents please email Head Office	
Belgium Linum Europe Ph: +32 (0)56 35 92 96	Noumea: Comptoir Materiel Professionnel Ph: +687 28 50 43
Fiji: Hotel Equipment Ltd Ph: +679 672 0666	Papua New Guinea: Brian Bell & Company Pty Ltd Ph: +675 325 5411
Germany Lolsburg Ph: +49 93059878-0	Singapore: Allied Foodservice Equipment Ph: +65 62525880
GREECE K&N Engineers Ltd Ph: +30 210 520 0440	South Africa Foodservice Solutions (Pty) Ltd Ph: +31 306 017 442
Hong Kong: Chung Wah Kitchen Machine Ltd Ph: +852 2334 5411	Thailand: Seven Five Distributors Co Ltd Ph: +662 866 5858
Italy NOAW Ph: +39 0331 219723	United Kingdom Metcalfe Catering Equipment Ph: +44 (0) 1766 830456
Malaysia: Allied Food Equipment Ph: +603 9133 5833	United Arab Emirates: Boncafe Middle East LLC +9714 282 8742
Maldives: Radiant Heat Maldives Pty Ltd Ph: +960 333 4845	United Arab Emirates: Nisa Trading LLC +9714 396 6132
New Zealand: Roband New Zealand Ph: +649 274 1354	U.S.A. Smart Kitchen Solutions Ph: +1 508 244 1365

© Copyright 2015 – Roband® Australia Pty Ltd

All rights reserved. No part of this work may be reproduced or copied in any form or by any means, electronic or mechanical, including photocopying or posting to a website, without the written permission of the publisher. The material contained within this document is intended entirely for instructional purposes.

CONTENTS

INTRODUCTION	1
GENERAL PRECAUTIONS	1
PACKAGING	2
COMPLIANCE	2
INSTALLATION	3
OPERATION - GENERAL	3
OPERATION - MODELS WITH THERMOSTAT CONTROL	4
GENERAL SAFETY	6
CLEANING, CARE & MAINTENANCE	7
TROUBLESHOOTING	8
SPECIFICATION	8
CIRCUIT DIAGRAMS	9
APPENDIX A	11
EC DECLARATION OF CONFORMITY	12
WARRANTY	15

INTRODUCTION

Congratulations on your purchase of this quality ROBAND® product. With proper care and management your new purchase will give you years of trouble free service.

By reading these instructions carefully you can ensure that this machine is used and maintained properly, helping your new investment to perform well for you now, and to continue performing in the many years to come.

GENERAL PRECAUTIONS

This machine must only be operated by qualified person(s) who are fully versed in the operating and safety instructions described in this manual. Servicepersons should be instructed to familiarise themselves with any and all safety instructions described in this manual prior to commencement of any maintenance or service.

In the case of new personnel, training is to be provided in advance. These machines should not be operated by persons (including children) with reduced physical, sensory or mental capabilities, or lack of experience or knowledge, unless they have been given supervision or instruction concerning the safe use of the appliance by a person responsible for their safety.



These machines are heating units, and as with any commercial heating unit the surfaces on these Bain Maries will get hot. Always be careful when near an operating Bain Marie, and ensure that any risk to unwary customers or staff is minimised with additional signage if necessary. Due to the obvious heat hazard Roband recommends that these units be kept out of reach of children.

Do not allow children to play with these units.

These Bain Maries are for use with food placed in pans. The performance of these units cannot be guaranteed for applications outside of its design intention.



The machine should be disconnected from all power and allowed to cool before cleaning.

Roband will accept no liability if;

- ◆ Non-authorized personnel have tampered with the machine.
- ◆ The instructions in this manual have not been followed correctly.
- ◆ Non-original spare parts are used.
- ◆ The machine is not cleaned correctly, with the right product.
- ◆ There is any damage to the unit.
- ◆ The machine has been modified in any way.

PACKAGING

All care is taken when packing and Roband ensures that every unit is functional and undamaged at the time of packaging.

The Package of these Bain Maries should include:

1. One Bain Marie (appropriate model)
2. Appropriate number of pans (depending on model ordered)
3. This manual
4. Packaging Materials

Any damage to the machine as a result of freight must be reported to the Freight Company and to the agent responsible for the dispatch of said unit within 24 hours of receipt. No claims will be accepted or entertained after this period.



RCM:

Roband® products have been designed and manufactured to comply with any and all specifications set out by the Australian Communications and Media Authority (ACMA) in regards to Electromagnetic Compatibility. As testament to such compliance these units bear the RCM symbol.

For further information contact the Australian Communications Authority, PO Box 13112, Law Courts, Melbourne VIC 8010.

CE:

Roband® products bearing the CE compliance mark have been designed and manufactured to comply with European Standards and Directives. A copy of the CE Declaration of Conformity is located at the back of these instructions.

INSTALLATION

Remove all the packaging materials and tape, as well as any protective plastic from the machine. Clean off any glue residue left over from the protective plastic using methylated spirit or white oil.

Place the Bain Marie on a firm, level surface in the required position. Adjust the feet if necessary to level the unit if the surface is slightly uneven. As a precaution, it is recommended that all non-metal bench top surfaces be protected from heat with some form of insulation. A piece of masonite, sheet metal, laminate or similar material would be sufficient for this task.

Before connecting the Bain Marie to the power supply ensure that all the controls are in the “OFF” position.

For all models plug the unit into a standard, single phase, 10Amp power point.

Always ensure the power cable is not in contact with hot parts of the Bain Marie when in use, and have any damaged power cord replaced immediately.

We recommend the use of an RCD (Residual Current Device) rated at not less than 30mA for circuit protection when using these units. Note that if one RCD is used to protect multiple circuit(s) with multiple mains outlets, the RCD shall be appropriately rated so as to accommodate the total accumulative permissible leakage current of all devices on each protected circuit(s). Refer to appendix A for more information.

OPERATION - GENERAL

To turn on the Bain Marie rotate the ON/OFF switch to the “ON” position. The Bain Marie tank element is controlled by an energy regulator, located on the control panel. The thermometer on the control panel has been designed to function as a guide for operation only. It reflects the temperature beneath the pans. The thermometer does **not** directly reflect the temperature of the food in the pans.



Control Panel Display for energy regulator control models

DRY OPERATION (MODELS BM2, BM21 AND BM4 ONLY)

Note: Do Not operate model BM1 and BM1 variants dry.

Place all the pans in the Bain Marie. Rotate the ON/OFF switch to the “ON” position. Set the energy regulator to the desired position and allow the Bain Marie to pre-heat for approximately 15 minutes before placing any food in the pans. An

operating position of around 2 to 2½ should suffice, but experience will dictate the best position for the particular food being displayed.



Please note: Care should be taken while operating dry not to leave the energy regulator on HIGH for extended periods. The build-up of excessive heat may damage the thermometer and significantly overheat the food contents in the pans.

WET OPERATION (MODELS BM1, BM2, BM21 AND BM4)

IMPORTANT: When using wet, only use clean distilled or filtered water. Hard Water (water with a high mineral content), Bore water or other poor quality water can cause accelerated corrosion and may void warranty.

For wet operation, the most important factor is the volume of water placed in the tank. The tank should be filled with fresh clean water to a level where it just touches the bottom of the element. The water level should **not** be so high as to touch the undersides of the pan. If the water level is too high, performance will be compromised.

Once the water has been placed in the tank, place all the pans in the Bain Marie. Rotate the ON/OFF switch to the “ON” position. Turn the energy regulator to **high** and pre-heat the Bain Marie, bringing the water up to a temperature of approximately 65-70°C. As a guide this will take approximately 20 to 30 minutes. When the water has reached this temperature, the food may be placed in the pans and the energy regulator can be returned to a lower, operating value. As for dry operation, around 2 to 2½ should suffice, but experience will dictate the best position for the particular food being displayed.

OPERATION - MODELS WITH THERMOSTAT CONTROL

MODELS BM1T, BM2T, BM21T AND BM4T

These models function in the same manner as the models BM1, BM2, BM21 and BM4 but are controlled by a thermostat instead of an energy regulator.

Note: These models can only be used for WET OPERATION.

IMPORTANT: When using wet, only use clean distilled or filtered water. Hard Water (water with a high mineral content), Bore water or other poor quality water can cause accelerated corrosion and may void warranty.

The thermometer on the control panel has been designed to function as a guide for operation only. It reflects the temperature beneath the pans. The thermometer does **not** directly reflect the temperature of the food in the pans.

Generally, the operating instruction for models BM1, BM2 & BM4 that are without thermostat control can be followed for the BM1T, BM2T and BM4T, with the exception of the control settings. The control settings for the “T” models are outlined below.

WET OPERATION (MODELS BM1T, BM2T, BM21T & BM4T)

An operating setting of 75-80°C should suffice and, whilst this type of operating results in a longer heat-up time, running costs will be lower and heating will be more even after the Bain Marie has reached operating temperature..

⚡ SAFETY ⚡

GENERAL SAFETY

This machine contains no user-serviceable parts. Roband Australia, one of our agents, or a similarly qualified person(s) should carry out any and all repairs. Any repair person(s) should be instructed to read the Safety warnings within this manual before commencing work on these units.



Steel cutting processes such as those used in the construction of this machine may result in sharp edges. Whilst any such edges are removed to the best of our ability it is always wise to take care when contacting any edge.

Particular care should be taken to avoid contact with any steel edge, and warnings should be given in regards to the danger of such contact to any repair or maintenance person(s) prior to commencement of any servicing.

Do not remove any cover panels that may be on the machine.

Keep your fingers clear of the louvres on the side of the unit.

This unit can get **very** hot, ensure everyone is aware that the machine is operating and take care to avoid contact with hot surfaces. Use gloves (or some other form of protection) when handling the Bain Marie.

National Standards exist outlining the positioning, spacing and ventilation requirements when installing new appliances. These Standards should be consulted and new equipment should be installed accordingly. In any situation where specifications allow a distance of less than 100mm we would still recommend that a well-ventilated air gap of not less than 100mm be maintained. If the machine is near particularly heat-sensitive materials common sense should be employed in determining sufficient distancing.



Always ensure the power cable is not in contact with hot parts of the machine when in use. Ensure that any damaged power cord is replaced before further use. These cords should be replaced by qualified service persons only.



Do not clean this unit with the use of a water jet or spray applicator.



Keep out of reach of children.



Electricity is dangerous, and can cause serious injuries and fatalities. Make sure that only qualified people service this machine.



Never try to move the machine while it is operating or while it is still hot after operation. Allow the machine to cool before attempting to move it.



Never leave an operating machine unattended.

CLEANING, CARE & MAINTENANCE

IMPORTANT: When using wet, Daily cleaning is required to avoid deposits building up which can cause corrosion. Never use caustic or abrasive cleaning chemicals or cleaning pads which can cause damage to the stainless steel.

Attention to regular care and maintenance will ensure long and trouble free operation of your Bain Marie. Although scheduled servicing is not required we do recommend you adopt a program of regular maintenance to ensure that the Bain Marie is clean and functional and to avoid inadvertently damaging the unit.

When the Bain Marie is being operated wet, it must be stressed that clean, fresh water should be used at all times. The addition of a slice of lemon or lemon drops to the water daily will help to prolong the life of the element.

Ensure the power is off and the Bain Marie is cool before attempting to clean any part of the machine. It is recommended that the water be allowed to cool before draining the tank. The tank and element can then be wiped clean. To clean the Bain Marie, use hot soapy water with a clean sponge or cloth. We recommend this be done daily to prolong the life of the element and tank. Do **not** use a metal scourer. In some areas hard water may cause a residue to build up on the surface of the tank and element. This should be removed to prevent any corrosion to the tank and/or element failure.

Although every care is taken during manufacture to remove all sharp edges, care should be taken when cleaning to avoid injury.

Particular care should be taken when cleaning under the rim of the tank to avoid contact with possible sharp edges.

 **Do not** immerse the Bain Marie in water or allow the ingress of water into the ventilation holes or controls. **Do not** clean this unit with the use of a water jet or spray applicator. Spray application cleaners are a leading cause of moisture ingress into the control switches and associated breakdowns.

 **CAUTION:** Although every care is taken during manufacture to remove all sharp edges, care should be taken when cleaning and handling the Bain Marie to avoid injury.

CAUTION: Some cleaning agents can damage stainless steel, usually through prolonged use. For this reason we recommend cleaning with soapy water. Any damage to the unit through the use of harsh or improper cleaning agents is entirely the fault of the user.

TROUBLESHOOTING

If the Bain Marie does not heat up check the following points before calling for service.

- ✓ The Bain Marie is plugged in correctly and the power is switched on.
- ✓ The ON/OFF knob is in the “on” position.
- ✓ The power point is not faulty.
- ✓ The energy regulator / thermostat are in the correct relative position.
- ✓ The energy regulator / thermostat knob is not loose or broken, rendering the switch inoperable.
- ✓ Check Appendix A on page 13 of this manual on RCD’S

Only after all these points have been checked should you call for service.

SPECIFICATION

Model	Power Source	Power Rating	Nominal Dimensions		
			Width mm	Depth mm	Height mm
BM1	230 Volts AC 50Hz	670 Watts	355	295	318
BM1T	230 Volts AC 50Hz	670 Watts	355	295	318
BM2	230 Volts AC 50Hz	1000 Watts	555	350	318
BM2-UK	230 Volts AC 50Hz	1000 Watts	555	350	318
BM2T	230 Volts AC 50Hz	1000 Watts	555	350	318
BM21	230 Volts AC 50Hz	1000 Watts	350	555	318
BM21T	230 Volts AC 50Hz	1000 Watts	350	555	318
BM4	230 Volts AC 50Hz	1200 Watts	675	560	318
BM4-UK	230 Volts AC 50Hz	1200 Watts	675	560	318
BM4T	230 Volts AC 50Hz	1200 Watts	675	560	318

Constant research and development may necessitate specification changes at any time.

CIRCUIT DIAGRAMS

MODELS: BM1, BM2, BM21 & BM4

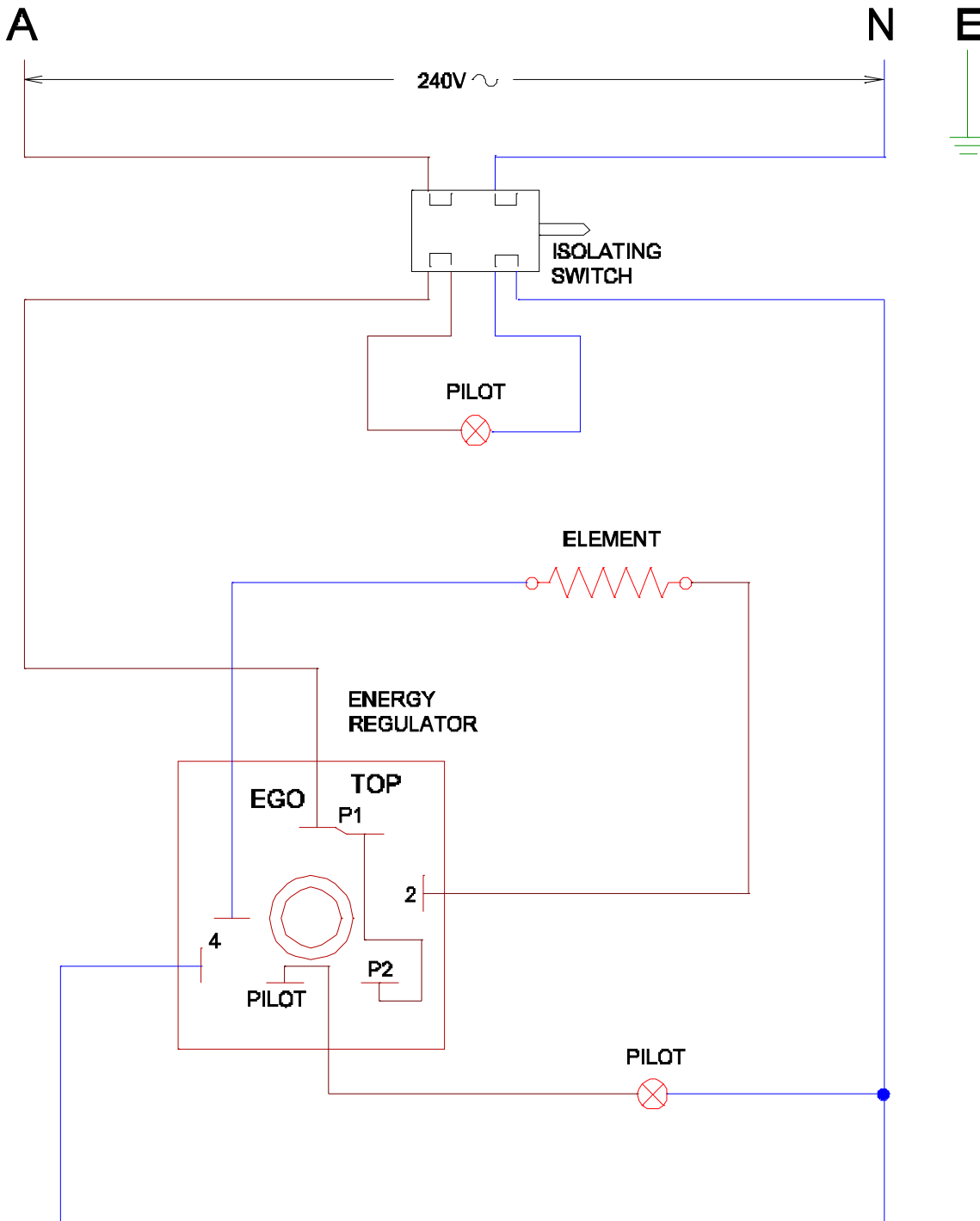

NOTE: This circuit diagram has been provided for reference and to assist qualified service and repair agents only. Under no circumstances should a person not suitably qualified attempt repairs to any electrical equipment.

MODEL: BM1T, BM2T, BM21T & BM4T

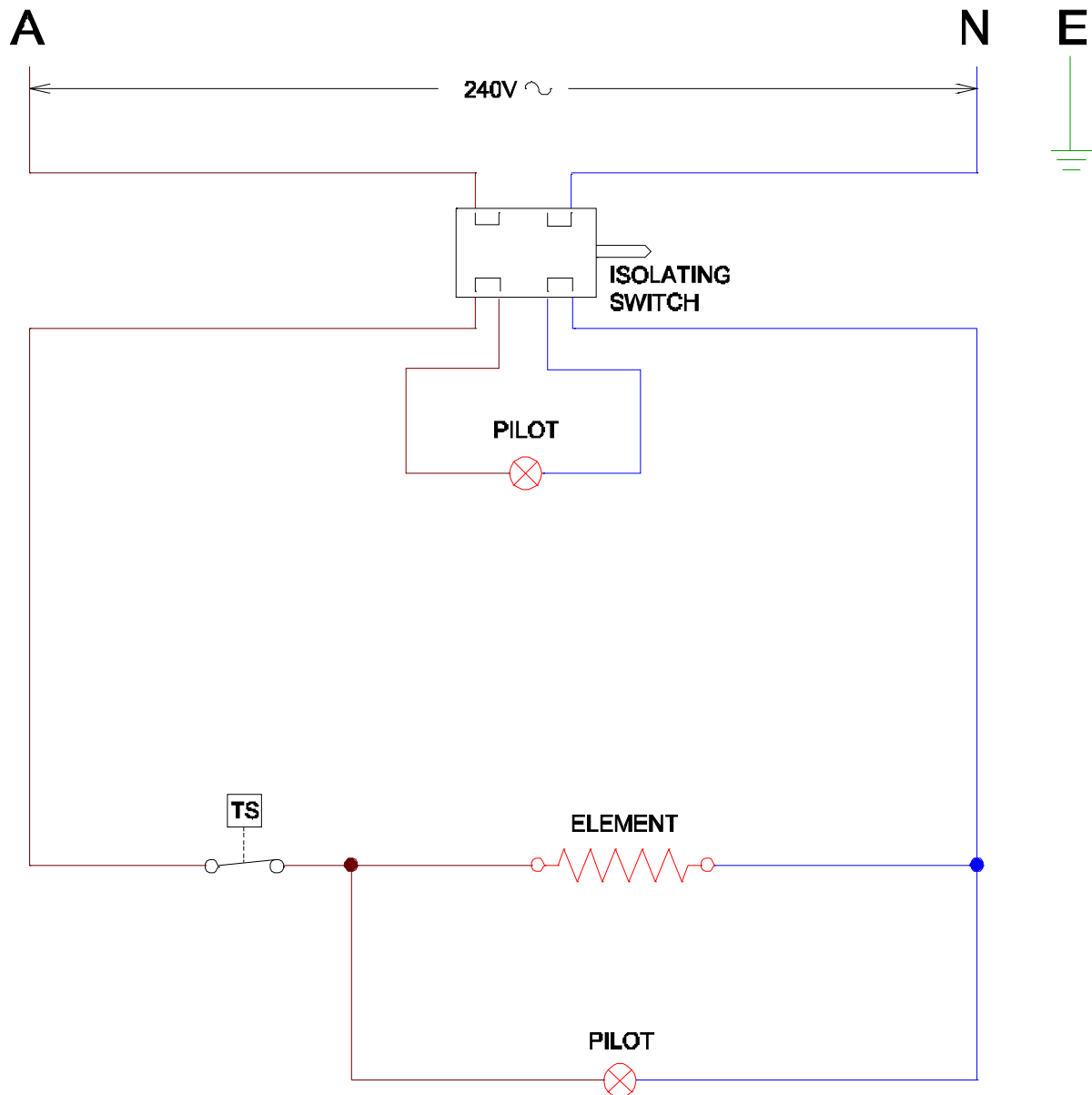

TS - Thermostat

NOTE: This circuit diagram has been provided for reference and to assist qualified service and repair agents only. Under no circumstances should a person not suitably qualified attempt repairs to any electrical equipment.

APPENDIX A

RESIDUAL CURRENT DEVICES (RCD'S)

Also known as Earth Leakage Protection systems, an RCD is a protective device that automatically disconnects the live conductors of a circuit when an earth leakage current reaches a predetermined value.

Australian and International Standards detail when and where RCD's are to be used in electrical installations, but common practice in many countries is to use a 30mA RCD in general commercial applications. This is typically done because 30mA RCD's are readily available and are used in domestic installations.

For commercial installations, and for socket-outlets providing power to commercial heating equipment (Toasters, Bains Marie, Grillers), 30mA RCD's are typically unsuitable unless they are protecting only one device. Higher rated RCD's should be considered if protecting multiple socket-outlets, giving appropriate consideration to the type of equipment being protected.

AS/NZS3000 2.5.2 gives the following warnings that should have been taken into consideration when an RCD circuit was installed.

To avoid unwanted tripping due to leakage currents and transient disturbances, care should be taken to ensure that the sum of the leakage currents of electrical equipment on the load side of an RCD is less than 1/3 of its rated residual current.

To avoid excessive leakage current causing unwanted tripping where socket-outlets are protected by one RCD having a rated residual current not greater than 30mA, consideration should be given to the number of socket-outlets protected and the nature of electrical equipment likely to be connected to the socket-outlets.

Tubular elements (such as those used in this unit) reaching temperatures greater than 110°C are subject to moisture absorption and therefore earth leakage current generation. Should the installation and use of this unit trip an RCD the unit will need to be run on a circuit without an RCD for approximately 30-60 minutes, after which time the elements should have dried out and the machine should function normally. If you are unable to locate a circuit without an RCD please contact your supplier or contact Roband or our Agent for alternative suggestions.

EC DECLARATION OF CONFORMITY

Manufacturer	Roband Australia 1 Inman Rd Cromer NSW, 2099 Australia
Model Type	Bain Marie
Description	Bain Marie-Counter Top
Date of first CE Marking	1 st March 2008
Specific Models	BM4, BM4T, BM4-UK, BM2, BM2T, BM2, BM21T, BM2-UK, BM1, BM1T

STANDARDS:

This machine is designed in compliance with

- Machinery Directive 2006/42/EC
- Low Voltage Directive 2006/95/EC
- EMC Directive 89/336/EEC including amendments to 93/68/EEC
- WEEE Directive 2002/96/EC (WEEE)
- Restriction of Hazardous Substances in Electrical and Electronic Equipment 2002/95/EC (RoHS)
- EN60335.1 Household and similar Electrical Appliances
- EN60335-2-48 Commercial Electric Toasters and Grillers
- EN55014.2: 1997 Electromagnetic compatibility. Requirements for household appliances, electric tools and similar apparatus. Immunity.

ENVIRONMENTAL:

This product is designed in order to contribute as little as possible to the quantity and noxious nature of waste and risk of pollution or other environmental contamination.

Packaging materials used in this machine are designed to be recyclable.

DECLARATION

I hereby declare under our sole responsibility that the product mentioned above to which this declaration relates complies with the above-mentioned standard(s).

Roband Australia has appointed Valera Ltd as our EU Authorised Representative of :

5-7 The Glade Business Centre, Eastern Ave, West Thurrock, Essex, RM203FH , UK.
Tel: 08 45 270 4321 Fax: 0845 270 4323 E-Mail : info@valera.co.uk



Signature of Authorised Person: _____

Date: 1st Sep 2010

Print Name: Mal Johnston

Position: Director of Engineering

NOTES

This page is intentionally left blank. Please note your favourite settings here.

NOTES

This page is intentionally left blank. Please note your favourite settings here.

WARRANTY

Every care is taken to ensure that no defective equipment leaves our factory and all goods manufactured by us are guaranteed against defective workmanship and materials for a period of 12 months from the date of purchase. Roband Australia's obligations pursuant to this express warranty being limited to the repair or replacement of the defective goods or materials, at its option and subject to the terms contained within this Warranty statement. Where relevant, glass, Teflon® and lamps are **not** included in this warranty and RCD tripping due to moisture absorption by Tubular Heating Elements is not considered a warranty fault.

Generally, all goods claimed under this warranty must be returned to the factory or an authorized service agent, freight prepaid, for inspection. All parts deemed to be defective will be replaced, however, no claims will be entertained for second hand products, or parts damaged in transport, misused or modified in any way without our approval. For machines that are not considered to be portable (e.g. food bars, rotisseries, large hotplates and some bain maries), on site warranty service will be provided in capital city metropolitan areas only. In all other locations, the customer is responsible for all travelling time/service call costs and payment for this will be required prior to the commencement of the repair. The labour costs to actually repair the fault will be met by the company.

Any repairs or replacement of defective goods or materials pursuant to this warranty, must be authorized by Roband Australia prior to any action being taken. The company reserves the right to reject a claim for warranty if it is not completely satisfied with the circumstances under which it occurred and any other costs incurred for false claims or faults due to incorrect usage etc. are the responsibility of the claimant. Roband Australia Pty Ltd nor any subsidiary company or Agent shall be liable for loss of profit or damage to other equipment and property except where it is in breach of the guarantees provided in accordance with Schedule 2 of the Competition and Consumer Act 2010 (Cth) or the applicable legislation from time to time.

The goods come with guarantees that cannot be excluded under the Australian Consumer Law (ACL). You are entitled to a replacement or refund for a major failure and for compensation for any other reasonably foreseeable loss or damage. You are also entitled to have the goods repaired or replaced if they fail to be of acceptable quality and the failure does not constitute a major failure.

Generally, authorized service agents are located in all areas which have authorized distribution dealers. For the name of your nearest Australian authorised service agent, please contact:

Roband Australia Pty Ltd

1 Inman Road, Cromer, NSW 2099

Warranty Number: 1800 268 848

Phone: (02) 9971 1788 Fax: (02) 9971 1336

All other countries please contact your selling Agent.

Please complete the following details and keep this card in a safe place.

NAME _____

ADDRESS _____

MODEL No: _____ SERIAL No: _____ DATE PURCHASE _____

NAME OF DEALER: _____

PLEASE RETAIN THIS SECTION FOR YOUR RECORDS

DO NOT POST

ROBAND® AUSTRALIA PTY LTD

OTHER LEADING PRODUCTS AVAILABLE:



Sycloid Toaster



DRINK MIXERS

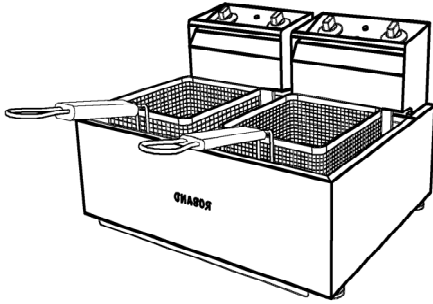

HIGH PERFORMANCE DEEP FRYERS

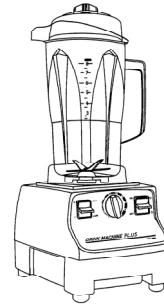

VITAMIX BLENDERS

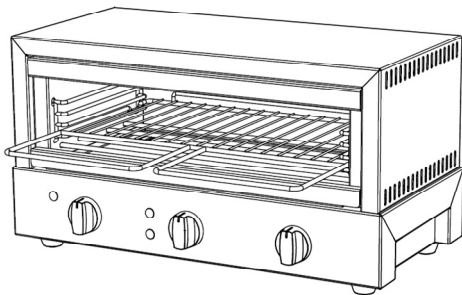

GRILLMAX TOASTERS

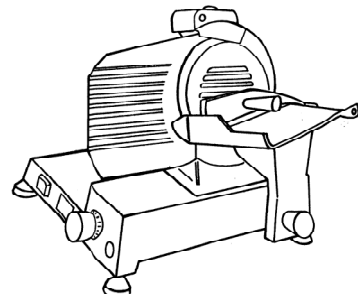

NOAW Slicers

Manufactured/Imported in Australia by:

ROBAND® 

Authorised Distributor/Agent