



MANUFACTURED BY
ROBAND AUSTRALIA PTY LTD

ASSEMBLY INSTRUCTIONS

STAINLESS STEEL FOOD BAR TROLLEYS & PANELS





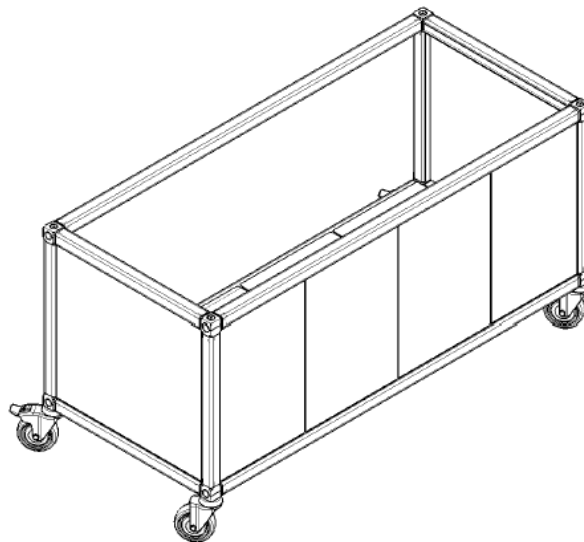





**Models: ET22, ET23, ET24, ET25 & ET26
ETP22, ETP23, ETP24, ETP25 & ETP26**

Version 2 Units

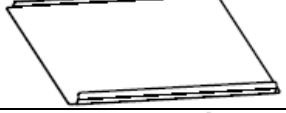

These instructions cover the models of ROBAND® Stainless steel trolleys and panels listed above. Although there are slight variances between them, the installation, operation, care and maintenance procedure is the same for all.

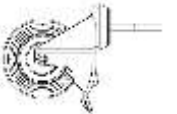
Quantities

Parts No.'s/ Contents	ET22	ET23	ET24	ET25	ET26	Diagrams
Pre Assembled bag Packed in castor box	1	1	1	1	1	4 x DC0103  4 x DC0104  8 x PC0326 
4 X MS0427- 455mm Vertical Frame (preassembled) 4 x DC0103 4 x DC0104 4 x MC0761	4	4	4	4	4	
4 X MS0428- 504.5mm Short Horizontal frame (preassembled) 8 x DC0105 8 x MC0084	4	4	4	4	4	
4 X MS0390-MS0394 Long Horizontal Frame (preassembled) 8 xDC0105 8 x MC0084	4	4	4	4	4	
SS2131 Small Shelf Panel	2	2	2	2	2	
SS2130 Large Shelf Panel	0	1	2	3	4	
MC0151 Locking Castors	2	2	2	2	2	
MC0150 Plain Castors	2	2	2	2	2	
5mm Allen Key Packed in castor box	1	1	1	1	1	

Note: As illustrated some parts are pre-assembled

INSTALLATION

Remove all the packaging materials and tape, as well as any protective plastic from the unit. Clean off any glue residue left over from the protective plastic using methylated spirit. Do not remove the double-sided adhesive tape at this stage.

Tools

To assemble the trolley the following tools are required.

- Rubber or wooden mallet.
- Allen Key. (Supplied in kit)

Please note: If you use a metal hammer, place a block of wood on the metal parts and strike the wood to prevent damage to the metal parts.

ET24 Step-by-Step Instructions

Instructions are the same for every model, but the frame sizes and number of panels differs.

1. Organise the frame to resemble below

(Please note that all the Horizontal bars should have end fittings screwed into either end of them.)

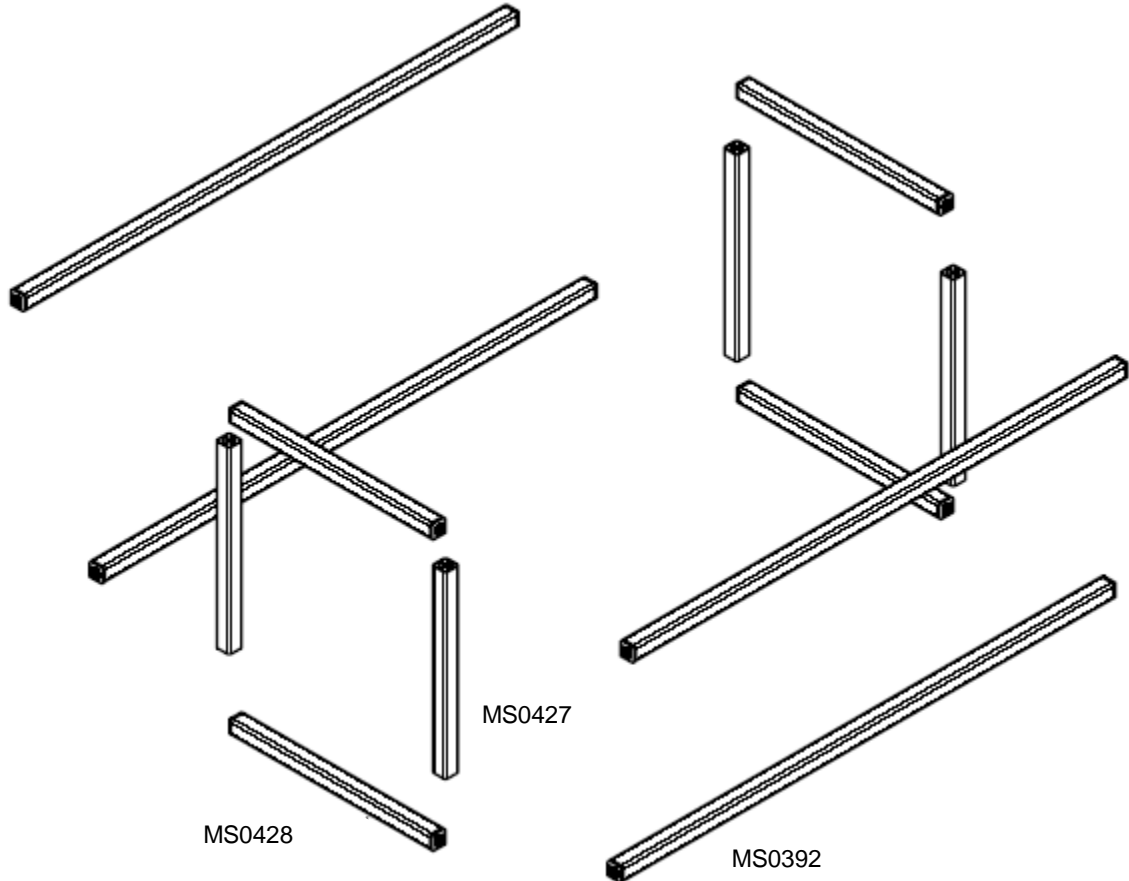

2. Select the 3 bars above labelled above and start to assemble the trolley frame. Insert the joiner into the vertical leg of the trolley (labelled MC0427) the flat straight side of the joiner should face to the front. The legs should fit tightly into the joiner you may need so use the mallet to gently tap into place.

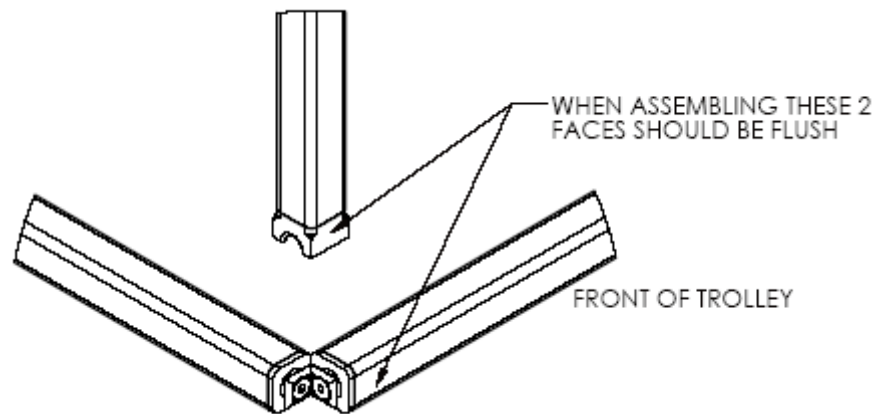

3. Once in place, the joiner cover can be inserted on, the same way the legs were inserted on to the joiner. The blanking plug is also inserted now. This is placed in the spare joiner circle, to cover up the spare joiner hole. Don't screw together yet.

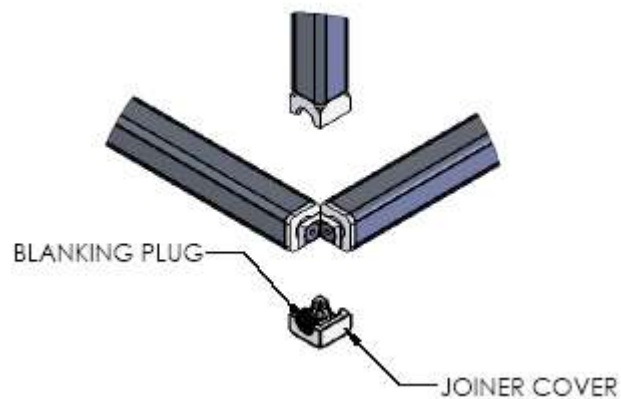

4. Now that this corner of the frame is together, connect the 3 other corners this way. Again not screwing them together.



5. Insert Joiners into the other end of the vertical bars again making sure the joiners flat ends are flush.

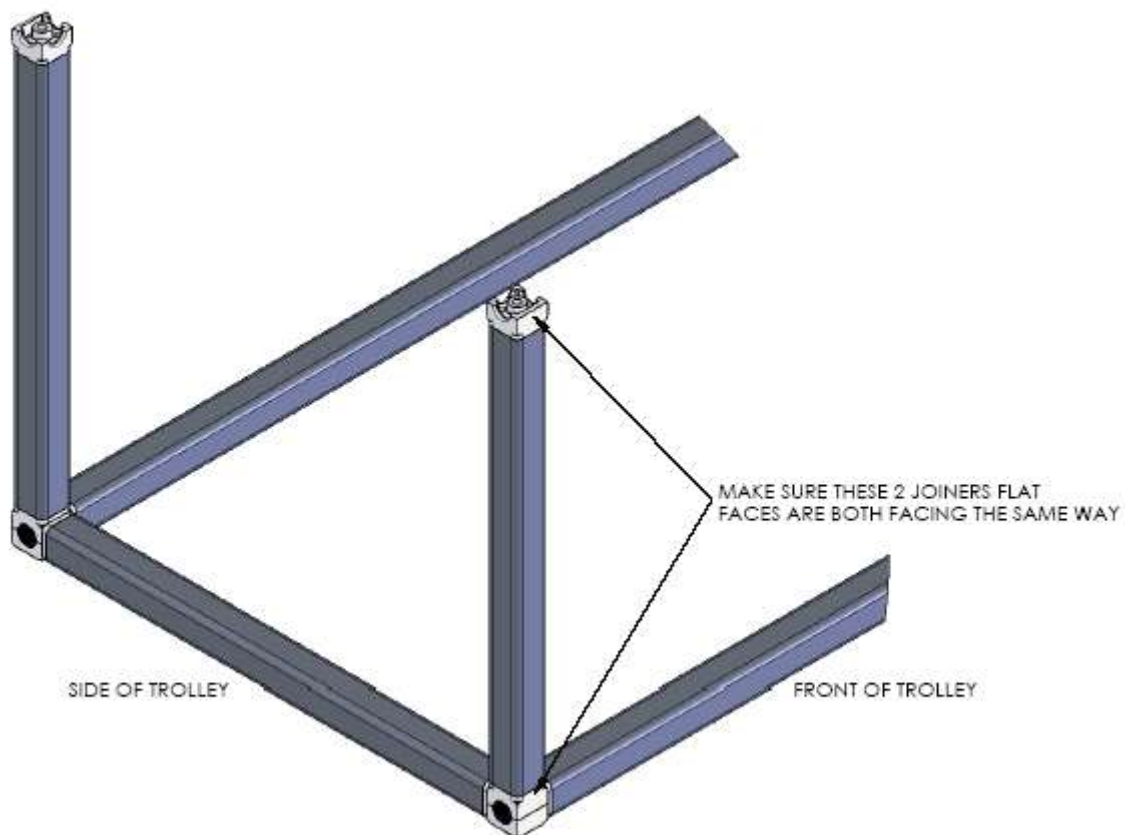

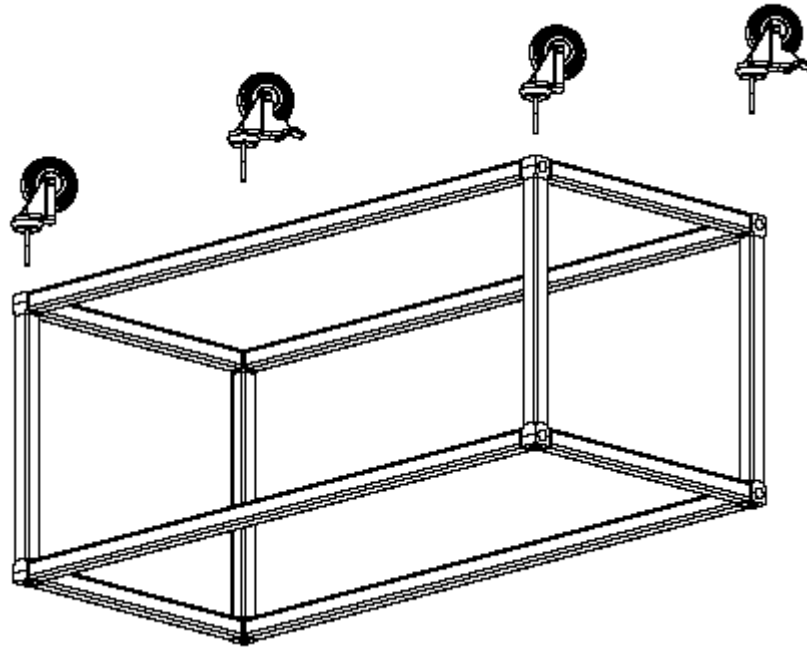

6. As in the previous steps attach the joiners and blanking plug to the corners. Now attach the castors using the screws provided. Use the Allen key to tighten the screws as in the following diagram. Note that the screws for the castors will form their own thread as they are screwed into the legs. Note that two of the castors include a locking device these should be assembled on one long side of the trolley usually the side on which the operator serves from.

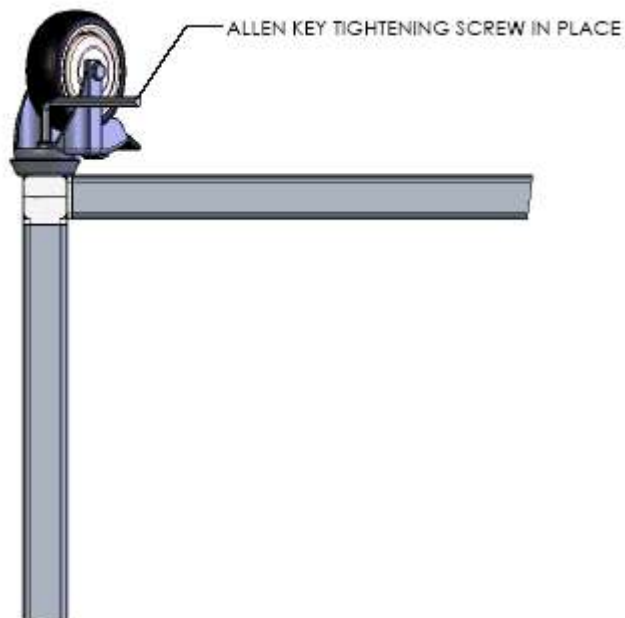

7. Now flip the trolley over carefully, and insert the screws into the top joiner covers, and tighten. Again, the screws will form their own thread in the extruded legs as the screw is tightened.

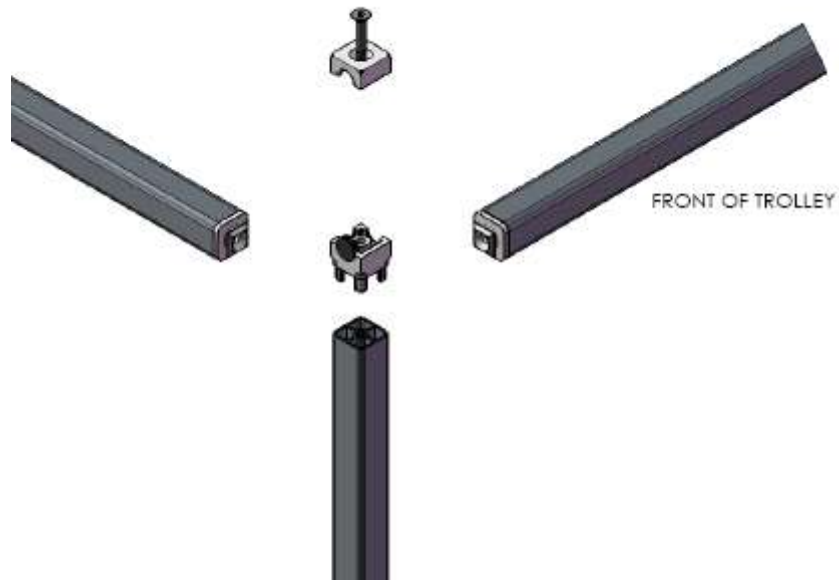

Your trolley frame should now be tightly secured together and resemble the diagram below.



Inserting Shelf Panels

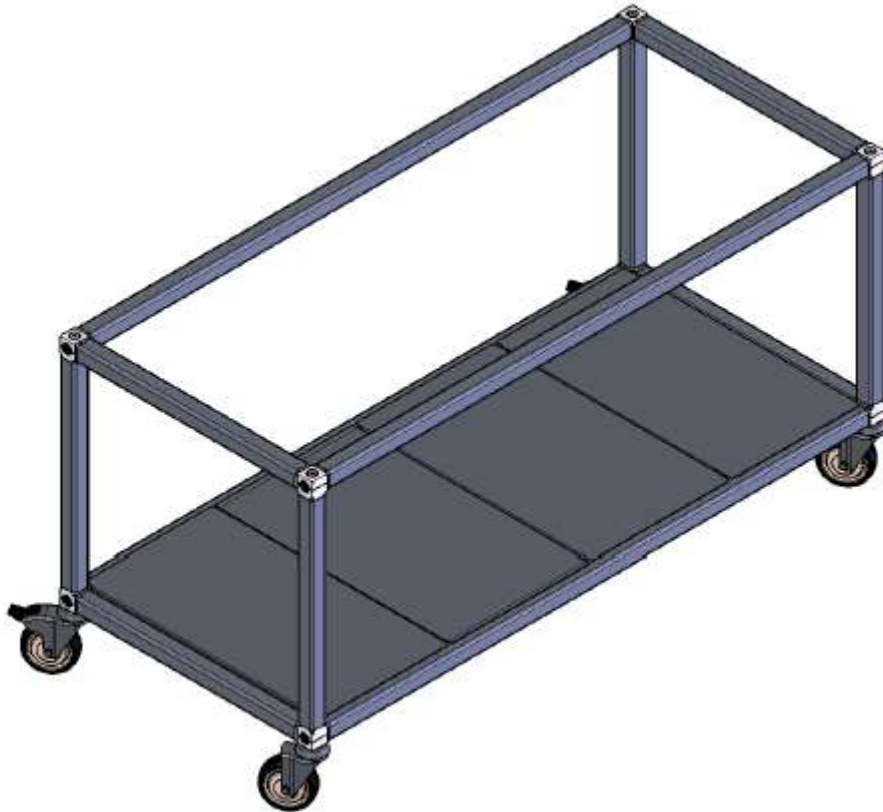

ET series trolleys are supplied with the shelf panels. Refer to page 1 for quantities. Note that ETI series trolleys **do not** have shelf panels supplied.

Note: If you have purchased ETP panels with your trolley then assemble those panels first, before you install the shelf panels. Refer to page 9 for this step and return to this step after the ETP panels have been installed.

1. Wipe down the trolley frame removing any excess machine oil.
2. Peel the plastic protective coating off the shelf panels.
3. Place the smaller outer shelf panels (300mm wide) in place first. If your trolley has been supplied with additional larger shelf panels (325mm wide) then place them in between the outer panels to complete the shelf. These panels do not require any fixing the simply lay in position on the trolley frame. Refer to the image below.

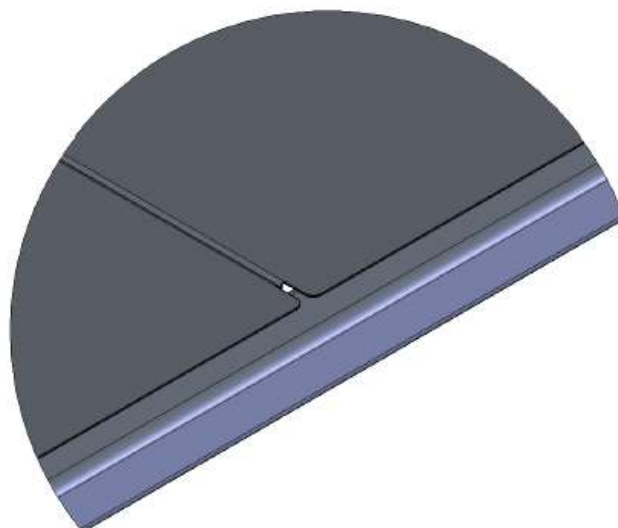

ETP Series optional panels.

Size	ET Series panels		ETP Series panels (charges additional)		
	Shelf Outer Panels	Shelf Centre Panels	End Panels	Front Outer Panels	Front Centre Panels
22	2	-	2	2	-
23	2	1	2	2	1
24	2	2	2	2	2
25	2	3	2	2	3
26	2	4	2	2	4

Note: All ETP panels are supplied with double sided tape to fix them in position. This tape should be stuck to the trolley frame rail at the top of the frame not to the rail closest to the castors.

1. Wipe down the trolley frame removing any excess machine oil.
2. The end panels are inserted into the trolley frame first. Below is a picture of the end panel inserted in position. The panels should slot into the frame neatly with the flanges of the panel sitting square with the trolley frame.

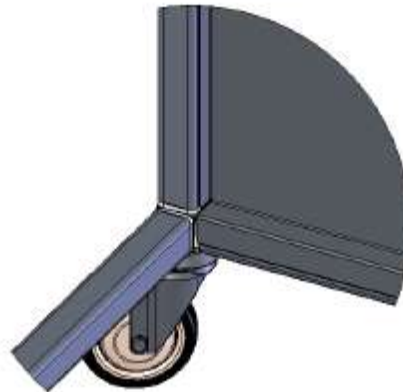

3. Insert the front panels in the same manner but **do not stick them down yet.** Install the smaller outer panels (300mm wide) first. If your ETP set has been supplied with additional larger panels (325mm wide) then place them in between the outer panels. These panels have been designed to have a 1mm gap on either side of each panel once installed. Before you stick them in position, arrange them so that this clearance is achieved and hold them temporarily in place with some sticky tape. Once you are happy with their positions, use the supplied double sided tape to stick them permanently one at a time.

The Dark Panels illustrate how the front and end panels rest on the trolley frame.

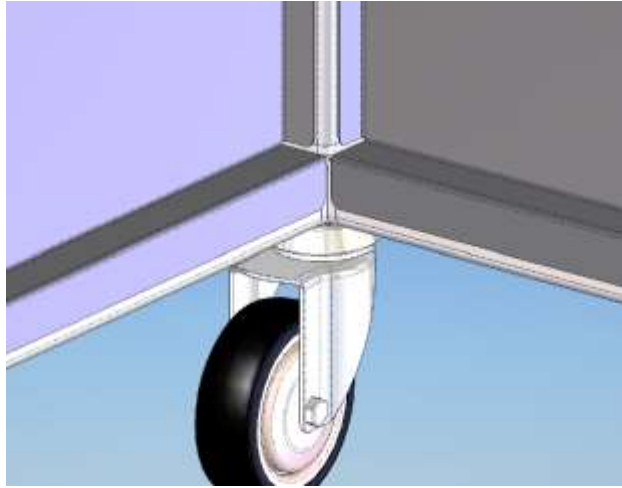

3. Lastly, fit the shelf panels in place. Refer to page 8.

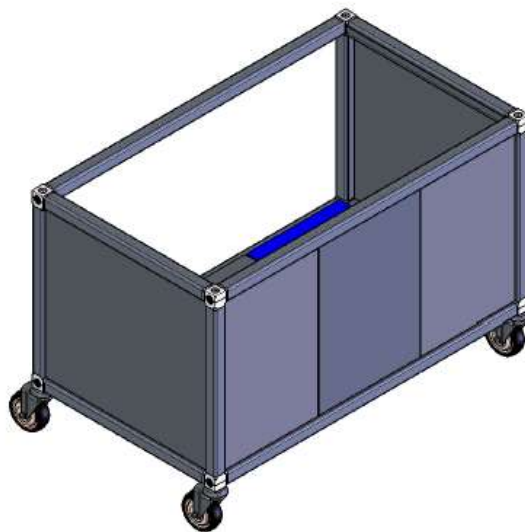
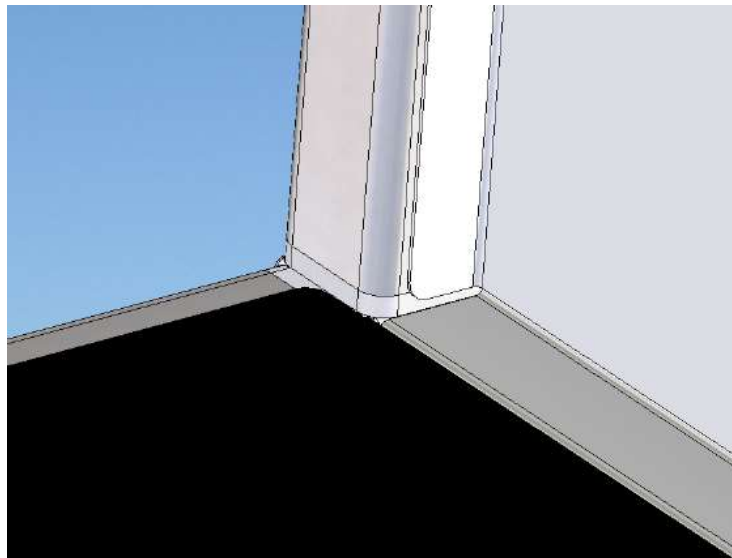

NOTES

This page is intentionally left blank. Please note your favourite settings here.

NOTES

This page is intentionally left blank. Please note your favourite settings here.