



# Electric Soup Warmer

## MODEL SW1200

### Instructions For The Electric Soup Warmer

#### Specifications

Capacity:	11.4 Quart (10.8 Ltr)
Voltage:	220 V ~ 240 V AC 475 W ~ 580 W
Weight:	6.2 Kg
Dimensions:	370 mm High, 405 mm Diameter



#### Operation and Maintenance:

- Plug unit into correct electrical outlet rated 10 Amp or greater.
- Add 0.8 litre of water between the stainless steel bowl and internal aluminium liner. Never overfill with water and under no circumstances should the stainless steel bowl float up, even when empty. Remove excess water immediately.
- In areas of hard water (especially South Australia & Western Australia) demineralised water needs to be used. The high mineral content in hard water can react with the aluminium in the liner and cause tiny holes after a period of time.
- The temperature control should be set between 1 and 3 (setting will vary with liquid viscosity) for keep warm function. For cooking use high (6) setting.
- The cooking feature is for slow-cooking/simmering purpose. For faster preparation please heat up the soup in a separate pot on stove first, then transfer the soup to the stainless steel bowl. Prolonged use on high will produce condensation. In such cases the unit may appear to be "leaking."
- Always unplug from the electrical outlet after use.
- Always keep the removable hinged lid attached and in the closed position when not serving.
- Never move or carry the kettle when the unit contains hot soup or liquid.
- Spilled food should be removed immediately from all exterior surfaces. The body exterior and top collar should be cleaned with a damp cloth.
- Make sure the unit is unplugged while not in use, when filling with soup or water and when being cleaned.
- Staff should be given adequate training before using this machine. This machine is not suitable for unsupervised operation by children or the infirm. It is recommended that this unit be kept out of reach of children.
- Replace any damaged cord prior to further use.
- This unit is not suitable for cleaning with the use of a water-jet.
- When cleaning, use only soapy water - other cleaning chemicals can damage the aluminium liner.

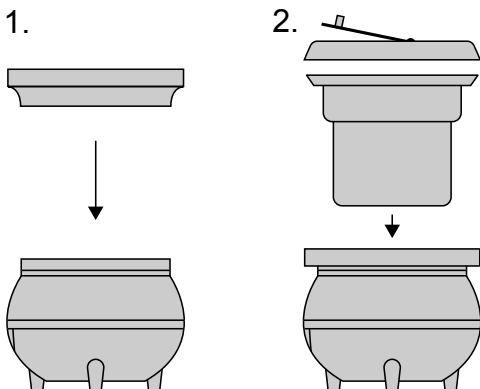

**IMPORTANT - NEVER IMMERSE UNIT IN WATER.**

**WARNING - THIS APPLIANCE MUST BE EARTHED.**

**! - DO NOT OPERATE EMPTY UNIT.**