

ROBAND®

MANUFACTURED BY:

ROBAND®
AUSTRALIA PTY LTD

OPERATING INSTRUCTIONS

Grill Station *HIGH SPEED CONTACT GRILL*

Models: GSA610S, GSA610ST, GSA610R, GSA610RT
Version 2 Units

Models: GSA810S, GSA810ST, GSA810R, GSA810RT
GSA815S, GSA815ST, GSA815R, GSA815RT
Version 1 Units

(Includes EXPORT models: -UK, -F)

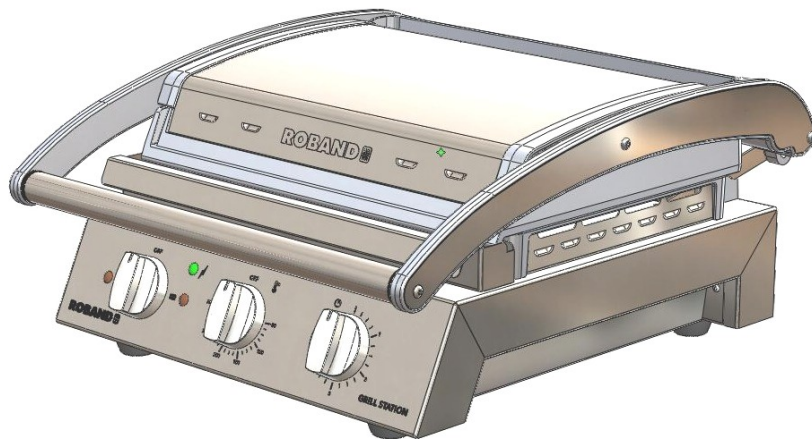

Special Features:

Timer Alarm

Advanced Control Safety Systems

Embedded elements for Rapid heating, fast recovery and maximum life,
High Quality, Rapid Heating Aluminium, Non stick Coating (T) series.



These instructions cover the models of ROBAND® Grill Station Automatic toasters and grillers listed above. Although there are slight variances between models, the installation, operation, care and maintenance procedure is the same for all.



Roband Australia is a wholly Australian owned company and has been manufacturing quality commercial catering equipment for the food service industry for more than 50 years. Roband products are engineered and manufactured to the highest standards to provide functionality, reliability and durability, and our quality products are exported world-wide.

Included in the comprehensive ROBAND® range are Toasters, Fryers, Milkshake Mixers, Rotisseries, Food Display Cabinets and much more.

Roband Australia also acts as the Australian agents for Vitamix® Blenders, NOAW® Meat Slicers, RYNO™ Stainless Benching, Ceado® Juicers, Forge® Cookware, Robalec™ Soup/Rice Warmers & Robatherm™ Urns .

In addition to a vast range of machines, Roband Australia has its own line of commercial cookware and cutlery under the Robinox® brand name.

For a complete set of brochures please contact your nearest authorised dealer or contact Roband directly at our head office.

Roband Head Office Sydney Australia	International Agents For additional agents please email Head Office
Roband Australia Pty Ltd 1 Inman Road DEE WHY NSW 2099 Australia Tel: +61 2 9971 1788 Fax: +61 2 9971 1336 Email: sales@roband.com.au Web: www.roband.com.au	Cyprus: United Catering Equipment Supplies Ph +357 777 777 24 Fiji: Hotel Equipment Ltd Ph +679 672 0666 Hong Kong: Chung Wah Kitchen Machine Ltd Ph +852 2334 5411 Italy: World Group Ph +39 0322 83 67 24 New Zealand Roband New Zealand Ph +649 274 1354 Papua New Guinea: Brian Bell & Company Pty Ltd Ph +675 325 5411 Singapore: Jelco Private Ltd Ph +65 5611 988 Switzerland: Burgi Infra Grill Ph +41 418 554 552 Thailand: Seven Five Distributors Co Ltd Ph +662 866 5858 United Arab Emirates: Technical Supplies and Services Co Ph +971 4343 1100 United Kingdom: Metcalfe Catering Equipment Ph +44 1766 830 456

© Copyright 2011 – Roband Australia Pty Ltd

All rights reserved. No part of this work may be reproduced or copied in any form or by any means, electronic or mechanical, including photocopying or posting to a website, without the written permission of the publisher. The material contained within this document is intended entirely for instructional purposes.

CONTENTS

INTRODUCTION	4
GENERAL PRECAUTIONS	4
PACKAGING	5
COMPLIANCE	5
INSTALLATION	6
OPERATION	7
COOKING GUIDELINES	9
GENERAL SAFETY	10
CLEANING, CARE & MAINTENANCE	11
SPECIAL NOTES REGARDING NON STICK COATED EQUIPMENT	13
TROUBLESHOOTING	14
SPECIFICATIONS	15
CIRCUIT DIAGRAM	16
GSA6 EXPLODED VIEW	17
GSA6 PARTS LIST	19
GSA8 EXPLODED VIEW	20
GSA8 PARTS LIST	22
APPENDIX A	23
EC DECLARATION OF CONFORMITY	26
WARRANTY	27

INTRODUCTION

Congratulations on your purchase of this quality ROBAND® product. With proper care and management your new purchase will give you years of quality service.

By reading these instructions carefully you can ensure that this machine is used and maintained properly, helping your new investment to perform well for you now, and to continue performing in the many years to come.

GENERAL PRECAUTIONS

This machine must only be operated by qualified person(s) who are fully versed in the operating and safety instructions described in this manual. Operators should be instructed to familiarise themselves with any and all safety instructions described in this manual prior to commencement of any maintenance or service.



These machines are heating units, and as with any commercial heating unit the surfaces on these Grills will get hot. Always be careful when near an operating Grill Station, and ensure that any risk to unwary customers or staff is minimised with additional signage if necessary. Due to the obvious heat hazard Roband recommends that these units be kept out of reach of children.

In the case of new personnel, training is to be provided in advance. These machines should not be operated by persons (including children) with reduced physical, sensory or mental capabilities, or lack of experience or knowledge, unless they are being supervised or being instructed concerning the safe use of the appliance by a person responsible for their safety.



The machine should be disconnected from all power and allowed to cool before cleaning. Any damaged plug or cord should be replaced before further use.

These machines should not be cleaned with the use of a spray applicator, water jet or any other method except those outlined in the Cleaning & Care section of these instructions.

Roband will accept no liability if;

- ◆ Non-authorized personnel have tampered with the machine.
- ◆ The instructions in this manual have not been followed correctly.
- ◆ Non-original spare parts are used.
- ◆ The machine is not cleaned correctly, with the right product.
- ◆ There is any damage to the unit.

PACKAGING

All care is taken when packing and Roband ensures that every unit is functional and undamaged at the time of packaging.

The Package of these grills should include:

- 1) One High Speed Grill Station (appropriate model)
- 2) This manual
- 3) Grease Box
- 4) Nylon Spatula
- 5) Packaging inserts

Any damage to the machine as a result of freight must be reported to the Freight Company and to the agent responsible for the dispatch of said unit within 24 hours of receipt. No claims will be accepted or entertained after this period.



COMPLIANCE

C-Tick:

ROBAND® products have been designed and manufactured to comply with any and all specifications set out by the Australian Communications Authority (ACA) in regards to Electromagnetic Compatibility. As testament to such compliance these units bear the C-Tick symbol.

For further information contact the Australian Communications Authority, PO Box 13112, Law Courts, Melbourne VIC 8010.

CE:

ROBAND® products bearing the CE compliance mark have been designed and manufactured to comply with European Standards and Directives. A copy of the CE Declaration of Conformity is located at the back of these instructions.

INSTALLATION

Remove all the packaging materials and tape, as well as any protective plastic from the machine. Clean off any glue residue left over from the protective plastic.

Place the Grill Station on a firm, level surface in the required position. Before connecting the grill to the power supply ensure that all the controls are in the "OFF" position. Turn all controls on and off to familiarise yourself with their operation.

National Standards exist outlining the positioning, spacing and ventilation requirements when installing new appliances. These Standards should be consulted and new equipment should be installed accordingly. In any situation where specifications allow a distance of less than 100mm we would still *recommend* that a well-ventilated air gap of not less than 100mm be maintained. If the machine is near particularly heat-sensitive materials common sense should be employed in determining sufficient distancing.

Do not place the Grill Station above other equipment that may give off heat.

AUSTRALIAN Models

For the GSA610 and GSA810 models plug the machine into a single phase, 10 Amp power point. For the GSA815 models, plug the grill into a single phase 15 Amp power point. The GSA815 models will not plug into a 10 Amp power point.

EXPORT Models (-UK and -F Models)

All export models can plug into a standard 13 Amp United Kingdom (Type G) or 16 Amp European (Type E or F) power point .

For all units a *minimum* clearance of 25mm is required at the back of the unit to allow the arms to pivot freely preventing damage to any adjacent wall or equipment. Any damage caused to adjacent surfaces or equipment as a result of the unit being too close to a wall will not be covered by warranty. Roband recommends a minimum gap of 100mm be maintained all around the unit to allow adequate ventilation and to prevent any damage to heat sensitive materials.

We recommend the use of an RCD (Residual Current Device) rated at not less than 30mA for circuit protection when using these units. Note that if one RCD is used to protect multiple socket outlets, the RCD shall be appropriately rated so as to allow up to 30mA from these machines alone.

OPERATION

Initial Startup

To turn on the unit, turn the **Selector** switch either left or right (see below).

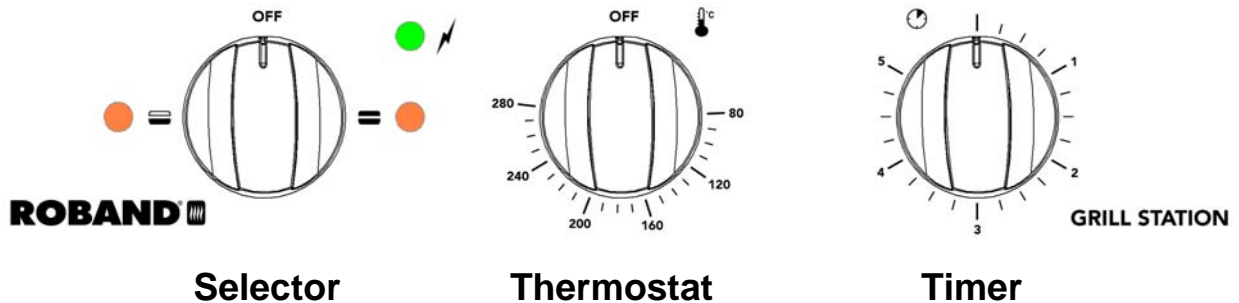

Controls Description

Selector	<p>The Selector switch displays the different cooking and plate combinations possible on this unit. The green pilot light above and to the right of the switch will illuminate whenever the unit is switched on, in either mode of operation, indicating that power is being supplied to the unit.</p> <p>Contact Grill Mode: Turning the switch to the right activates both the top and bottom plates of the unit and turns on the right hand amber indicator light, allowing the unit to function as a contact grill.</p> <p>Hotplate Mode: Turning the switch to the left activates the bottom plate only and turns on the left amber indicator light.</p> <p>Off: To turn the unit off, return the switch to the Off position.</p> <p>Note the “Top & Bottom” and “Top” amber indicator lights glow only when the unit is heating and turns off when the unit reaches the temperature set on the Thermostat.</p>
Timer	<p>The Timer is purely a mechanical device to provide an audible ring after the set time. It provides no electrical control over the unit.</p>
Thermostat	<p>The Thermostat controls the temperature of the plates. The temperature can be selected by using the dial indicator, which are in 10 degree increments. The maximum temperature of the thermostat is 280°C, However most cooking is carried out between 180°C and 240°C. For non stick coated units, this Thermostat should never be set above 240°C. It is not necessary to turn the Thermostat to "Off" when the unit is switched off.</p>

Seasoning

NOTE: ONLY REQUIRED FOR UNITS WITHOUT NON STICK COATING ON PLATES

Before cooking for the first time the plates need to be seasoned as follows.

- ◆ Wipe the top and bottom plates clean and apply a liberal coating of paraffin or vegetable oil.
- ◆ Turn both plates on by rotating the **Selector** switch to the “Top & Bottom” position marked .
- ◆ Set the thermostat to 180° by rotating the **Thermostat** knob. The pilot lights will illuminate indicating that the grill is heating.
- ◆ When the Grill Station has reached the set temperature the amber pilot lights will extinguish. Wipe the excess oil from the plates. (**Caution: Take care when wiping excess oil off plates as plates and oil will be hot.**)

Cooking

- ◆ Lightly grease or oil the plates and set the **Thermostat** to the desired cooking temperature. See the cooking guidelines for more information.
- ◆ Allow a warm up time of around 15 minutes to pre-heat the plates before using for the first time each day.
- ◆ Place the food on the bottom plate and close the top plate onto the food
- ◆ A timer is provided with all GS Series Grill Stations. This timer should be used as a guide only. **Warning** the timer does not turn off the heating elements when the bell sounds.
- ◆ For NON STICK coated plates: Do not use metal spatulas, scrapers, tongs and knives as described in the SPECIAL NOTES REGARDING NON STICK COATED EQUIPMENT.

It is recommended that the plates be kept closed when not cooking to minimise heat loss, and to avoid high temperatures in the handle. While closed for extended periods, the temperature can be turned down to around 150° idle position to save power.

CAUTION:

During *hotplate mode* (with Top Plate turned off), the heat from the bottom plate will flow upwards and warm the handle. Although it should not get too hot, care should be taken when touching the handle during and after Hotplate operation.



Additionally, when operating do not leave the plates open for extended periods whilst in *contact grill mode* (both hotplates on), because the handle will become hot to touch.

Cooking Guidelines

The following table shows cooking times and temperatures for common food types that be used on the contact grill. Times based on GSA815 and GSA610 models. GSA810 can expect slightly longer times.

1. Individual experimentation is always necessary - this is a guide only
2. Table assumes cooking in Contact Grill Mode - both top and bottom plates operating

Item	Cooking Temp	Cooking Time	Other
20mm Steak <i>Medium Rare</i>	240°C	1min 30sec	Rest* for 3 minutes
20mm Steak <i>Medium</i>	240°C	2 mins	Rest* for 3 minutes
20mm Steak <i>Medium Well</i>	240°C	2mins 30 sec	Rest* for 3 minutes
Meat Patties	240°C	1 min 10sec	
Chicken Breast	240°C	3 mins	Rest* for 5 minutes
Foccacia <i>Ham, Cheese, Tomato</i>	220°C	2 mins 20sec	
Turkish Rolls <i>Ham, Cheese, Tomato</i>	220°C	2 mins 30sec	
Sandwich <i>Ham, Cheese, Tomato</i>	220°C	50 secs	
Wrap <i>Chicken, Cheese, Tomato</i>	220°C	1 min 15 sec	
Fish Fillet <i>Wrapped in Foil</i>	230°C	1 min 30 sec	Rest* for 1 minute
Eggs <i>In Egg Ring</i>	210°C	2 mins	
Bacon	210°C	30 secs	

*to Rest - place cooked food directly from Grill Station onto a ceramic plate, cover with aluminium foil and seal around edges.

SAFETY

GENERAL SAFETY

This machine contains no user-serviceable parts. Roband Australia, one of our agents, or a similarly qualified person(s) should carry out any and all repairs. Any repair person(s) should be instructed to read the Safety warnings within this manual before commencing work on these units.



Steel cutting processes such as those used in the construction of this machine result in sharp edges. Whilst any such edges are removed to the best of our ability it is always wise to take care when contacting any edge. Particular care should be taken when panels are removed (eg during servicing) as this may expose sharp edges.

Do not remove any cover panels that may be on the machine.

This unit can get very hot, ensure everyone is aware that the machine is operating and take care to avoid contact with hot surfaces. Hot surfaces should be left well ventilated with an air gap of at least 100mm, though common sense should be used if the machine is near heat-sensitive materials.



Always ensure the power cable is not in contact with hot parts of the machine when in use. Ensure that any damaged power cord is replaced before further use.

Do not clean this unit with the aid of a Spray Applicator or Water Jet.

These units are not suitable for cleaning in a dishwasher and no parts of these machines (except the grease box) should ever be submerged in water.

Keep out of reach of children or the inept.

CLEANING, CARE & MAINTENANCE

Attention to regular care and maintenance will ensure long and trouble free operation of your Grill Station. Although scheduled servicing is not required we do recommend you adopt a program of regular maintenance to ensure that the Grill Station is clean and functional and to avoid inadvertently damaging the unit.

Daily cleaning should be considered mandatory for all cooking equipment. In order to ensure the cooking plates are cleaned properly and to avoid damage the instructions below should be followed.

- ◆ Plates should be seasoned as per the instructions when the machine is first purchased. Generally, this should only ever need to be done once. This “seasoning” of the plates reduces food product sticking, protects the plates, and helps to maintain the foods flavour.
- ◆ Plates should be cleaned at the end of each day using a soft cloth dampened with only hot soapy water, with the machine **turned OFF** but while the plates are still warm. ***Do not under any circumstances use abrasive cleaning compounds or caustic cleaning agents.***
- ◆ **NEVER** put cold water or ice on hot plates at a medium to high temperature. This may cause the plates to buckle due to the sudden change in temperature.

Non Stick Coated (T) Series

- ◆ Plates should be cleaned at the end of each day using a soft cloth dampened with only hot soapy water, with the machine **turned OFF** but while the plates are still warm.
- ◆ Any stubborn cooking residue should be carefully removed by gently scrubbing with a Nylon scrubber or scraper. We recommend the use of Nylon scrubbers. ***Do not under any circumstances use any metal or abrasive scrubbers or cleaners on non stick coated plates.***

Units without Non Stick

- ◆ We recommend the use of Nylon scrubbers when cleaning and scrubbing the plates, as the use of metal scrapers or highly abrasive scrubbers (such as steel wool) can prematurely wear and damage the plates.
- ◆ Using the scourer in the heel of your palm, you can put the weight of your upper torso behind the scrub and easily remove any built up residue. **Do not scrub back the plates too far!** If you scrub them so far back that they are shiny again, then you will need to re-season the plates. Remember that a light clean regularly is much easier than trying

to remove a large build-up of burnt on food and carbon. Occasionally you may find that the plates have become very difficult to clean. Should this occur, and only if necessary, use a **NON-CAUSTIC** oven cleaner, leaving it on for no longer than 30 seconds and if necessary repeat. Ensure all *cleaner residue* is removed.

(**Note:** some cleaning products are not as non-caustic as they say)



- ◆ **Wipe** down the remainder of the machine with a cloth or sponge that is only DAMP with soapy hot water, taking care to avoid water entering any part of the Grill Station. **Do not** clean with the use of a water jet, spray applicator or place the unit in a dishwasher. Spray applicators can result in liquid penetrating the switches on the machine, causing dangerous electrical situations, damage to the machine, and voiding any warranty.



- ◆ Use only soapy water on a damp cloth or sponge when cleaning (soapy water is made by adding mild hand dishwashing detergents to water). Other cleaning chemicals can result in damage to parts of the machine. Many cleaning chemicals are unsuited to polycarbonates or plastics, and may also damage stainless steel and aluminium.



- ◆ Although every care is taken during manufacture to remove all sharp edges, care should be taken when cleaning to avoid injury.

Maintaining Appearance of the Stainless

- ◆ For protection and cleaning of “brushed” stainless steel surfaces, it is best to use a cleaner that will both remove grease and dirt while protecting the surface from future marks. Whilst there are many possible products on the market, our tests have shown that the following products work well on brushed stainless surfaces.

- ◆ Stainless Steel Polish (Water based) - Supplied by Clean Plus Detergents Pty Ltd
- ◆ Simple Green Pro M cleaner – Supplied by Simple Green

SPECIAL NOTES REGARDING NON STICK COATED EQUIPMENT

The following instructions cover the models of ROBAND® equipment that are offered with non stick coating as an option.

The non stick coating utilised is high quality, however Roband Australia Pty Ltd cannot guarantee the performance or longevity of these coatings other than against faulty workmanship. This is the case due to the protective coating nature of the product and it's use in unknown commercial environments.

Attention to regular care and maintenance will ensure long and trouble free operation of your equipment. Always follow the care and maintenance procedure that is described in the operating instructions for your particular equipment and in addition to those, carry out the steps below.

The following list contains the recommendations from the manufacturer to maximise the life and performance of the non stick coating on your equipment.

- ◆ Do **NOT** use at high temperatures over 240°C.
- ◆ Do **NOT** use metal spatulas, scrapers, tongs or knives when transferring food in or out of the plates, or when scraping residue into the grease tray. Plastic tipped spatulas and tongs should be used at all times on non stick coated units.
- ◆ A non stick coating will not stop carbonisation of food that is left on the plates. Food that is carbonised is harder to remove, and reduces cooking performance. Avoid food carbonisation by cleaning regularly during normal use, by wiping with a plastic scraper, spatula or squeegee. The advantage of non stick coating is that wiping down often is easy.
- ◆ At the end of each day, use warm soapy water to clean the surface. A nylon brush or non-woven, nylon pot scourer can be used to assist in the removal of stubborn build up. Be careful to ensure that water does **not** penetrate into the equipment. **Never** put cold water on a warm or hot cooking surface.
- ◆ Using a little cooking oil will assist with particularly sticky substances.

TROUBLESHOOTING

If the grill does not heat up check the following points before calling for service.

- ✓ The grill is plugged in correctly and the power switched on.
- ✓ The power point is not faulty.
- ✓ The temperature has been set correctly and the green pilot light is illuminated indicating the machine has power.
- ✓ The **Thermostat** knob is not loose or broken, rendering the thermostat inoperable.
- ✓ Check Appendix A at the back of this manual - RCD'S

If the top plate is toasting faster than the bottom plate

- ✓ Check that there is no carbon build-up on the bottom plate. Carbon on the plates will act as an insulator and reduce toasting performance. Refer to "Cleaning Care & Maintenance".

If the top plate is not toasting

- ✓ Check that the unit is not switched to "Hotplate mode".

SPECIFICATIONS

Model	GSA610 models	GSA810 models	GSA815 models
Power Source	220-240 Volts AC	220-240 Volts AC	220-240 Volts AC
Power Frequency	50-60Hz	50-60Hz	50-60Hz
Power Consumption	2150-2250 Watts	2200-2400 Watts	2860-3120 Watts
Amps	9.6	10.0	13.0
Width mm	435	560	560
Height mm	220	220	220
Depth mm	490	490	490
Weight kg	17.3	23	23
Cooking Area mm	275 x 375	275 x 500	275 x 500

Constant research and development may necessitate specification changes at any time.

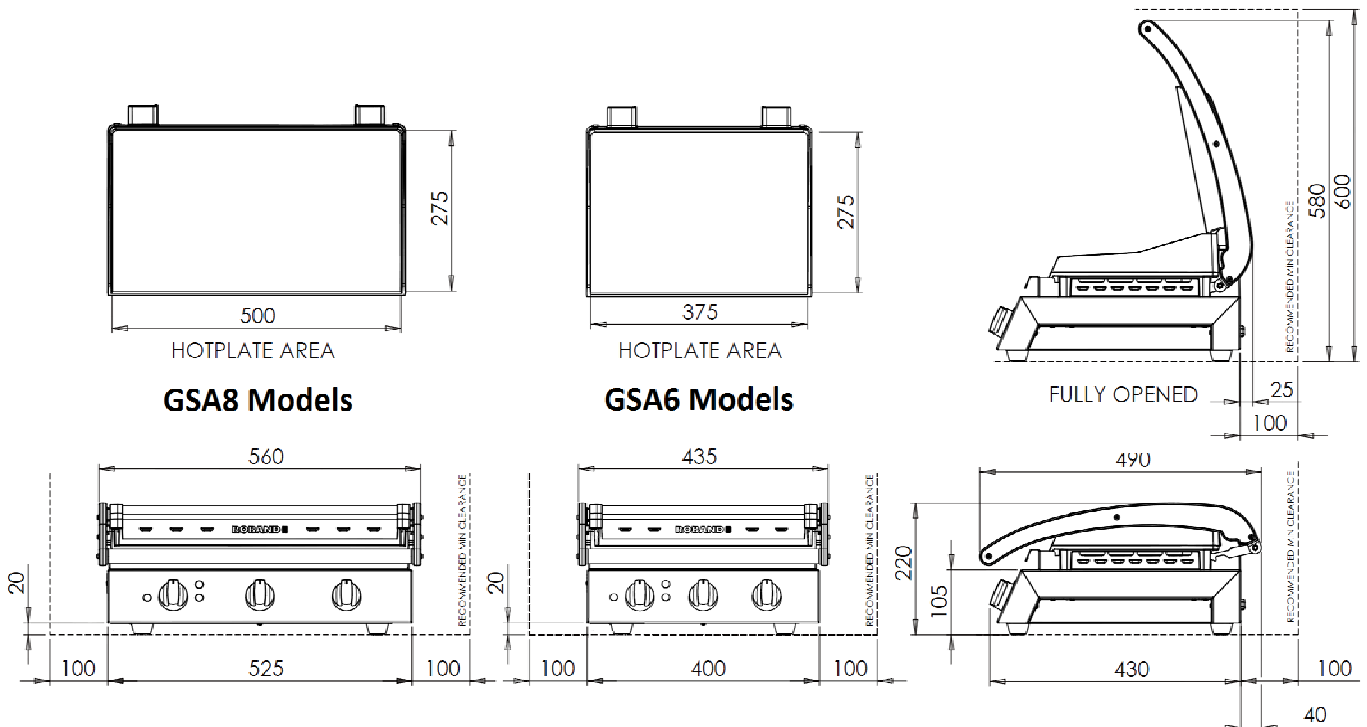

CIRCUIT DIAGRAM

All Models

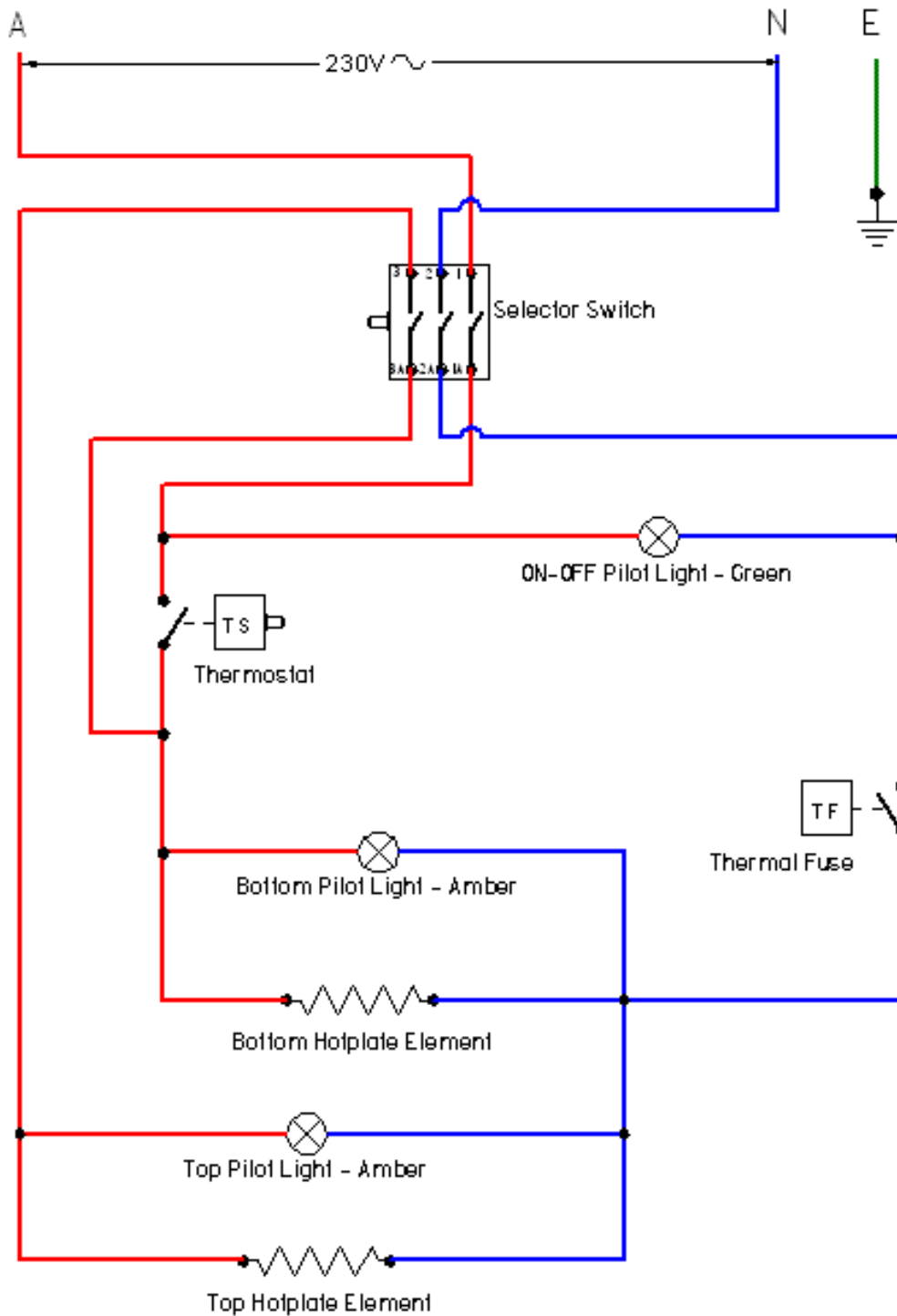

***This circuit diagram has been provided for reference and to assist qualified service and repair agents only. Under no circumstances should persons not suitably qualified attempt repairs to any electrical equipment.**

GSA6 EXPLODED VIEW

Top Section

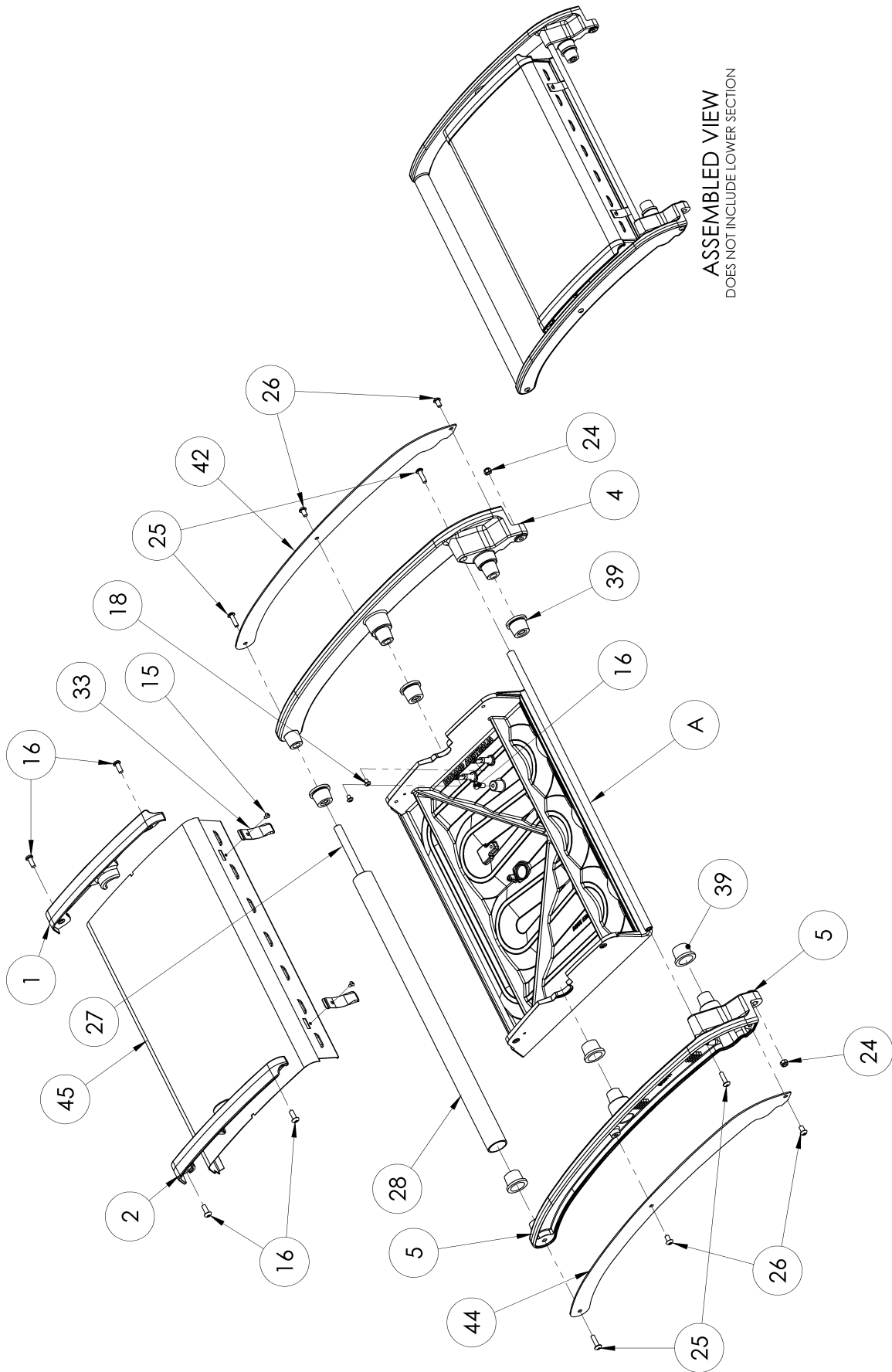

ASSEMBLED VIEW
DOES NOT INCLUDE LOWER SECTION

GSA6 EXPLODED VIEW

(continued)
Bottom Section

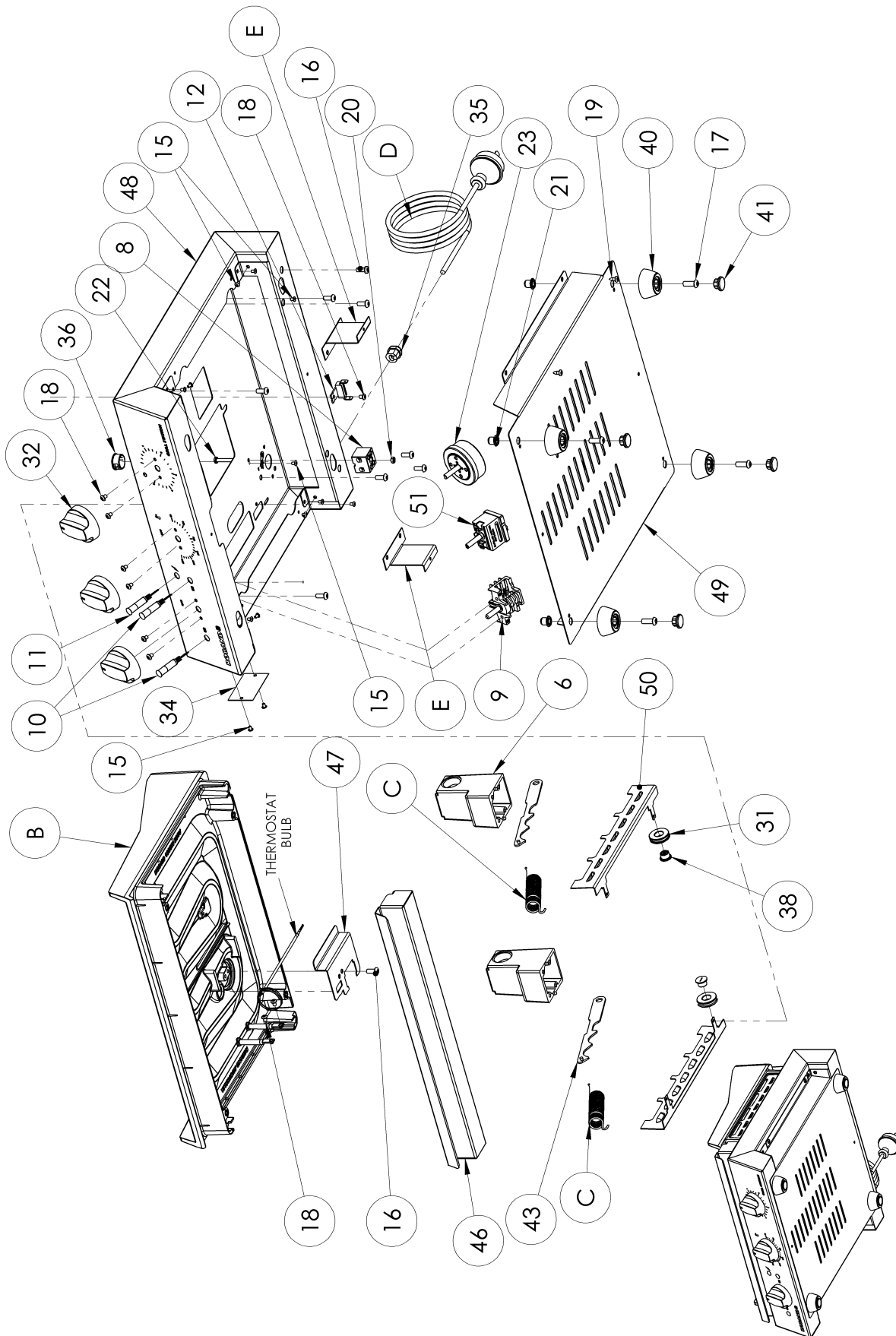

ASSEMBLED VIEW
DOES NOT INCLUDE UPPER SECTION

GSA6 PARTS LIST

COMMON PARTS FOR GS6 RANGE

ITEM NO.	PART NUMBER	QTY	DESCRIPTION
1	DC0113	1	Left Cover Retainer
2	DC0114	1	Right Cover Retainer
4	DC0116	1	Left Handle Arm
5	DC0117	1	Right Handle Arm
6	DC0118	2	Bearing Block
8	EC0031	1	Terminal Block - Porcelain
9	EC0209	1	Switch Rotary - 3 Pos - 3 Pole
10	EC0273	2	Pilot - Amber
11	EC0274	1	Pilot - Green
12	EC0377	1	Thermal Fuse 318°C
15	MC0283	15	Rivet - 73M5 4-1 Truss Head
16	MC0404	14	Screw M5 x 0.8 x 12L Button Head Socket SS
17	MC0405	4	Screw M6 x 1.0 x 16L Button Head Socket SS
18	MC0565	11	Screw M4 x 5 Button Head Top ZP
19	MC0584	4	8G x 3/8" Stainless self tapper
20	MC0688	1	Nut M4 Stainless Steel
21	MC0693	4	Nutsert - M6 Thin Sheet
22	MC0695	1	M4 x 25 SS Pan Hd
23	MC0697	1	Timer - 5 Minute Bell
24	MC0700	2	Nut - M5 - Zinc Plated Nylon Insert Lock Nut
25	MC0706	4	Screw - M5 x 16 - SS
26	MC0712	4	M5 x 8 SS T20 Hd
27	MC0840	2	Handle Spacer Bar

ITEM NO.	PART NUMBER	QTY	DESCRIPTION
28	MC0841	1	Handle Tube
29	MC0843	2	M5 x 12 Shoulder Screw
31	MC0845	2	Cam Roller
32	MC0846	3	2008 Knob - STD 6mm
33	MC0862	2	Spring Bumper
34	NC0005	1	Rating Plate
35	PC0060	1	Cord Clamp - 10A
36	PC0275	1	Bush 1/4" Nylon 6/6
37	PC0284	2	Cable Tie Black Nylon 6/6 75 x 2.2
38	PC0363	2	Cam Roller Bearing
39	PC0364	6	Bush - Handle
40	PC0392	4	Appliance Foot
41	PC0393	4	Appliance Foot Bung
42	SC0037	1	Left Arm Cover
43	SC0038	2	Cam Plate
44	SC0052	1	Right Arm Cover
45	SS2413	1	Top Cover
46	SS2415	1	Grease Box
47	SS2418	1	T/stat Sensor Brit
48	SS2419	1	Control Box
49	SS2420	1	Bottom Cover
50	SS2421	2	Skirt
51	TC0024	1	Thermostat 50-285°C

PARTS FOR GSA610S

ITEM NO.	PART NUMBER	DESCRIPTION	QTY
A	HC0168	Top Plate - Aluminium - Smooth - 1000W 230V	1
B	HC0169	Bottom Plate - Aluminium - 1200W 230V	1
C	MC0844	Tension Spring - SS - for GS Aluminium	2
D	EC0375	Plug and Cord - Elastomer - 10A	1

PARTS FOR GSA610R

ITEM NO.	PART NUMBER	DESCRIPTION	QTY
A	HC0184	Top Plate - Aluminium - Ribbed - 1000W 230V	1
B	HC0169	Bottom Plate - Aluminium - 1200W 230V	1
C	MC0844	Tension Spring - SS - for GS Aluminium	2
D	EC0375	Plug and Cord - Elastomer - 10A	1

GSA8 EXPLODED VIEW

Top Section

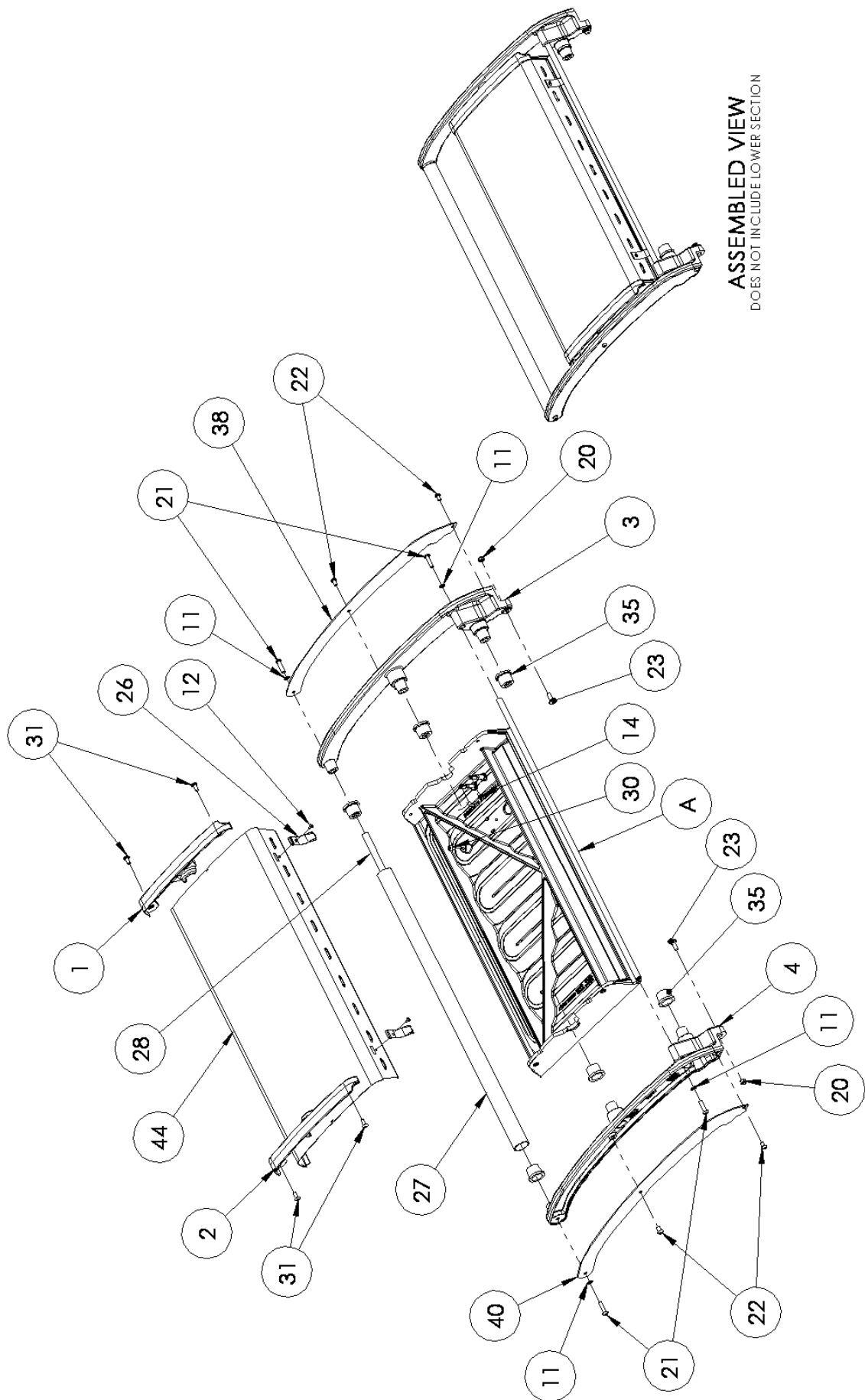

ASSEMBLED VIEW
DOES NOT INCLUDE LOWER SECTION

GSA8 EXPLODED VIEW

(continued)

Bottom Section

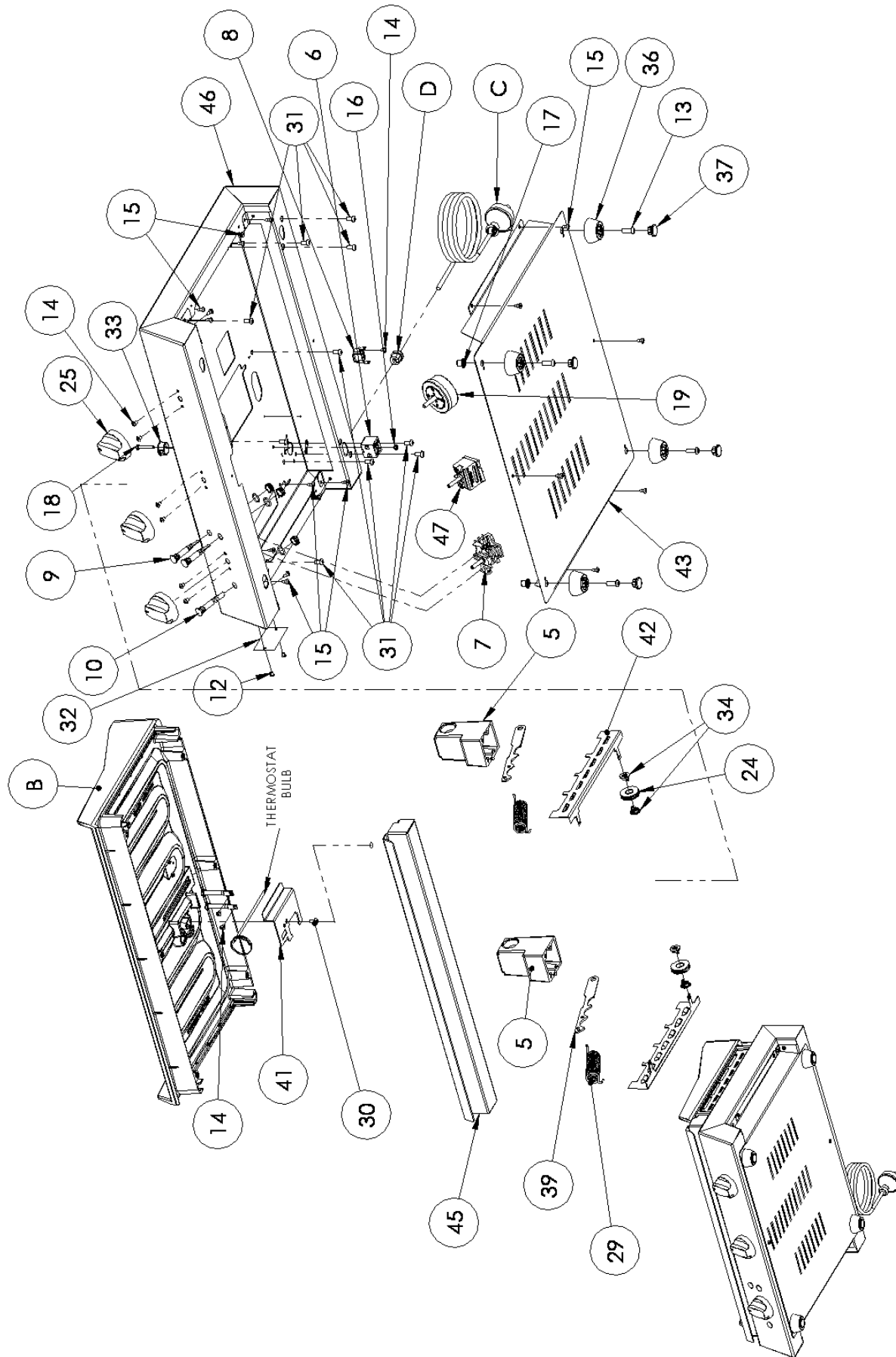

ASSEMBLED VIEW
DOES NOT INCLUDE UPPER SECTION

GSA8 PARTS LIST

COMMON PARTS FOR GS8 RANGE

ITEM NO.	PART NUMBER	DESCRIPTION	QTY	ITEM NO.	PART NUMBER	DESCRIPTION	QTY
1	DC0113	Left Cover Retainer	1	25	MC0846	Roband Knob - 6mm - Aluminium	3
2	DC0114	Right Cover Retainer	1	26	MC0862	Spring Bumper	2
3	DC0116	Left Handle Arm	1	27	MC0865	Handle Tube	1
4	DC0117	Right Handle Arm	1	28	MC0866	Handle Spacer Bar	2
5	DC0118	Bearing Block	2	29	MC0872	Tension Spring	2
6	EC0031	Terminal Block - Porcelain	1	30	MC0882	Screw M5 x 8 Button Hd Anti Sieze Torx SS	2
7	EC0209	Switch Rotary - 3 Pos - 3 Pole	1	31	MC0883	Screw M5 x 10 Button Hd Anti Sieze Torx SS	14
8	EC0377	Thermal Fuse 318°C non resetting	1	32	NC0005	Rating Plate	1
9	EC0395	Pilot - 10mm Amber (includes O-ring & Nut)	2	33	PC0275	Bush 3/4" Nylon 6/6	1
10	EC0396	Pilot - 10mm Green (includes O-ring & Nut)	1	34	PC0363	Cam Roller Bearing	4
11	MC0278	Washer - 3/16 Internal Star Shakeproof	4	35	PC0364	Bush - Handle	6
12	MC0283	Rivet - 73MS 4-1 Truss Head	4	36	PC0392	Appliance Foot	4
13	MC0405	Screw M6 x 16 Button Head Socket SS	4	37	PC0393	Appliance Foot Bung	4
14	MC0565	Screw M4 x 5 Button Head Torx ZP	11	38	SC0037	Left Arm Cover	1
15	MC0584	Screw 8G x 3/8" Self Tapper Torx SS	18	39	SC0038	Cam Plate	2
16	MC0688	Nut - M4 SS	1	40	SC0052	Right Arm Cover	1
17	MC0693	Nutsert - M6 Thin Sheet	4	41	SS2418	T/stat Sensor Brkt	1
18	MC0695	Screw M4 x 25 Pan Hd Torx SS	1	42	SS2421	Skirt	2
19	MC0697	Timer - 5 Minute Bell	1	43	SS2501	GS8 Bottom Cover	1
20	MC0700	Nut - M5 Nylon Lock ZP	2	44	SS2502	GS8 Top Cover	1
21	MC0707	Screw - M5 x 20 Button Head Torx SS	4	45	SS2503	GS8 Grease Box	1
22	MC0712	Screw - M5 x 8 Button Head Torx SS	4	46	SS2504	GS8 Control Box	1
23	MC0843	Screw M5 x 12 Button Hd Shoulder Torx SS	2	47	TC0024	Thermostat 50-285°C	1
24	MC0845	Cam Roller SS	2				

B

PARTS FOR GSA810S

PARTS FOR GSA815S

C

ITEM NO.	PART NUMBER	DESCRIPTION	QTY	ITEM NO.	PART NUMBER	DESCRIPTION	QTY
A	HC0190	Top Plate - Aluminium - Smooth - 890W 230V	1	A	HC0198	Top Plate - Aluminium - Smooth - 1170W 230V	1
B	HC0189	Bottom Plate - Aluminium - 1410W 230V	1	B	HC0197	Bottom Plate - Aluminium - 1820W 230V	1
C	EC0239	Plug and Cord - Elastomer - 10A	1	C	EC0306	Plug and Cord - Elastomer - 15A	2
D	PC0060	Cord Clamp - 10A	1	D	PC0061	Cord Clamp - 15A	1

PARTS FOR GSA810R

PARTS FOR GSA815R

ITEM NO.	PART NUMBER	DESCRIPTION	QTY	ITEM NO.	PART NUMBER	DESCRIPTION	QTY
A	HC0191	Top Plate - Aluminium - Ribbed - 890W 230V	1	A	HC0199	Top Plate - Aluminium - Ribbed - 1170W 230V	1
B	HC0189	Bottom Plate - Aluminium - 1410W 230V	1	B	HC0179	Bottom Plate - Aluminium - 1820W 230V	1
C	EC0239	Plug and Cord - Elastomer - 10A	2	C	EC0306	Plug and Cord - Elastomer - 15A	2
D	PC0060	Cord Clamp - 10A	1	D	PC0061	Cord Clamp - 15A	1

APPENDIX A

Residual Current Devices (RCD's)

Also known as Earth Leakage Protection systems an RCD is a protective device that automatically disconnects the live conductors of a circuit when an earth leakage current reaches a predetermined value.

Australian and International Standards detail when and where RCD's are to be used in electrical installations, but common practice in many countries is to use a 30mA RCD in general commercial applications. This is typically done because 30mA RCD's are readily available and are used in domestic installations.

For Commercial installations, and for socket-outlets providing power to commercial heating equipment (Toasters, Bains Marie, Grillers), 30mA RCD's are typically unsuitable unless they are protecting only one device. Higher rated RCD's should be considered if protecting multiple socket-outlets, giving appropriate consideration to the type of equipment being protected.

AS/NZS3000 2.5.2 gives the following warnings that should have been taken into consideration when an RCD circuit was installed.

To avoid unwanted tripping due to leakage currents and transient disturbances, care should be taken to ensure that the sum of the leakage currents of electrical equipment on the load side of an RCD is less than 1/3 of its rated residual current.

To Avoid excessive leakage current causing unwanted tripping where socket-outlets are protected by one RCD having a rated residual current not greater than 30mA, consideration should be given to the number of socket-outlets protected and the nature of electrical equipment likely to be connected to the socket-outlets.

Tubular elements (such as those used in this unit) reaching temperatures greater than 110°C are subject to moisture absorption and therefore earth leakage current generation. Should the installation and use of this unit trip an RCD the unit will need to be run on a circuit without an RCD for approximately 30-60 minutes, after which time the elements should have dried out and the machine should function normally. If you are unable to locate a circuit without an RCD please contact your supplier or contact Roband or our Agent for alternative suggestions.

NOTES

NOTES

EC DECLARATION OF CONFORMITY

Manufacturer	Roband Australia 1 Inman Rd Cromer NSW, 2099 Australia
Model Type	Grill Station (GSA6 & GSA8 Series Toasters)
Description	Contact Grill Toaster
Date of first CE Marking	1st Sep 2010
Specific Models	GSA610S, GSA610ST, GSA610R, GSA610RT GSA810S, GSA810ST, GSA810R, GSA810RT GSA815S, GSA815ST, GSA815R, GSA815RT Includes export model: -UK, -F

Standards:

This machine is designed in compliance with

- Machinery Directive 2006/42/EC
- Low Voltage Directive 2006/95/EC
- EMC Directive 89/336/EEC including amendments to 93/68/EEC
- WEEE Directive 2002/96/EC (WEEE)
- Restriction of Hazardous Substances in Electrical and Electronic Equipment 2002/95/EC (RoHS)
- EN60335.1 Household and similar Electrical Appliances
- EN60335-2-48 Commercial Electric Toasters and Grillers
- EN55014.2: 1997 Electromagnetic compatibility. Requirements for household appliances, electric tools and similar apparatus. Immunity.

Environmental:

This product is designed in order to contribute as little as possible to the quantity and noxious nature of waste and risk of pollution or other environmental contamination.

Packaging materials used in this machine are designed to be recyclable.

Declaration

I hereby declare under our sole responsibility that the product mentioned above to which this declaration relates complies with the above-mentioned standard(s).

Roband Australia has appointed Valera Ltd as our EU Authorised Representative of :

5-7 The Glade Business Centre, Eastern Ave, West Thurrock, Essex, RM203FH , UK.

Tel: 08 45 270 4321 Fax: 0845 270 4323 E-Mail : info@valera.co.uk



Signature of Authorised Person: _____

Date: 1st Sep 2010

Print Name: Mal Johnston

Position: Director of Engineering



WARRANTY

Every care is taken to ensure that no defective equipment leaves our factory and all goods manufactured by us are guaranteed against faulty workmanship and materials for a period of 12 months from the date of purchase. Glass, lamps and Teflon coatings are **not** included in this warranty. Generally, all goods claimed under this warranty must be returned to the factory or an authorised service agent, freight prepaid, for inspection. Any part deemed to be defective will be replaced, however, no claims will be entertained for parts damaged in transport, misused or modified in any way without our approval. For machines that are not considered to be portable (e.g. food bars, rotisseries, large hotplates and some bain maries), on site warranty service will be provided in capital city metropolitan areas only. In all other locations, the customer is responsible for all travelling time/service call costs and payment for this will be required prior to the commencement of the repair. The labour costs to actually repair the fault will be met by this company.

This company reserves the right to reject a claim for warranty if it is not completely satisfied with the circumstances under which it occurred and any costs incurred for false claims or faults due to incorrect usage etc. are the responsibility of the claimant. Under no circumstances shall Roband Australia Pty Ltd or any subsidiary company or Agent be liable for loss of profit or damage to other equipment and property.

Generally, authorised service agents are located in all areas which have authorised distribution dealers. For the name of your nearest authorised service agent please contact:

ROBAND AUSTRALIA PTY LTD

Warranty Number: 1800 268 848 (for Australian residents)
Phone: +61 2 9971 1788 Fax: +61 2 9971 1336
Email: warranty@roband.com.au

All other countries please contact your selling agent.

Please complete the following details and keep this card in a safe place.

NAME: _____

ADDRESS: _____

MODEL No.: _____ SERIAL No.: _____ DATE PURCHASED: _____

NAME OF DEALER: _____

PLEASE RETAIN THIS SECTION FOR YOUR RECORDS

DO NOT POST
ROBAND AUSTRALIA PTY LTD

OTHER LEADING PRODUCTS AVAILABLE:

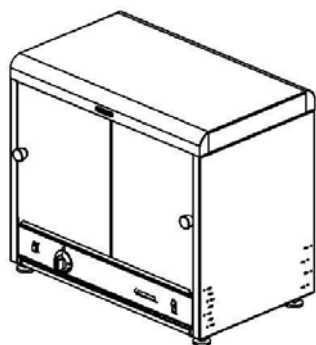

π-PLUS
PIE & FOOD WARMERS

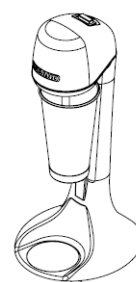

DRINK MIXERS

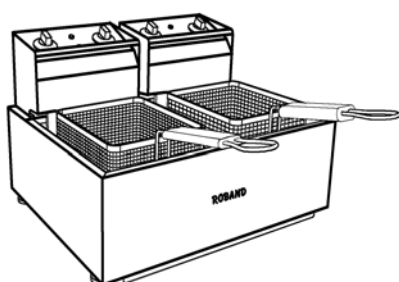

HIGH PERFORMANCE DEEP FRYERS

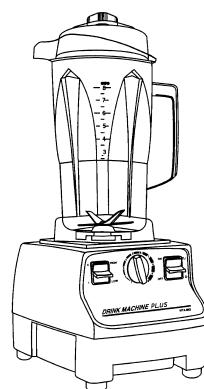

VITAMIX BLENDERS

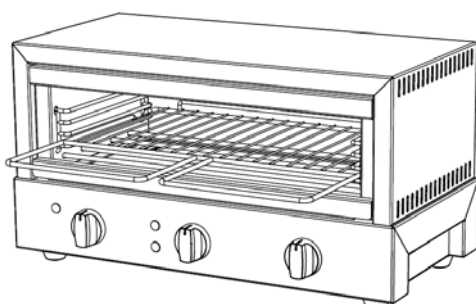

GRILLMAX TOASTERS

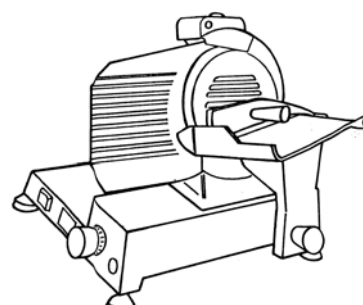

NOAW Slicers

Manufactured/Imported in Australia by:

ROBAND
AUSTRALIA PTY LTD

Authorised Distributor/Agent