



S E R I E S

STAINLESS STEEL
COOKWARE



Suitable for use with the following:



GAS



ELECTRIC



CERAMIC



INDUCTION



DISHWASHER

Stainless Steel Cookware

The Förje range of cookware is designed for professional cooking.

Designed with the high expectations of professional chefs in mind, Förje cookware is known for its robust construction and heat diffusing performance. With two grades of stainless steel (AISI 304 & AISI 430), encapsulating a 5 mm aluminium heat diffuser, this leading edge cookware is ideal for use on all heat sources including induction.

All items come complete with lids except frying pans and conical saucepans. Lids are available to suit.

Features

Heat diffusing heavy duty bases



Cut-away view of the base of Förje cookware which is manufactured using three-ply technology (stainless-aluminium-stainless) for fast, even and efficient heat distribution. The aluminium is fully encapsulated on all units up to 340 mm in diameter.

Satin finish



The interior and exterior finish of all Förje cookware and lids is in 'fine satin'. This makes for easy cleaning and reduces the signs of use.

Suitable for use with the following:



Saucepan handles



Förje saucepans are fitted with tubular stainless steel handles welded to the body. Items with a capacity greater than 7 litres have the extra support of stainless steel rivets.

Frying pan handles



All Förje frying pans have tubular stainless steel handles. These are fitted to the pans with stainless steel rivets and on non-Excalibur® items, they are also welded for extra strength.

Stock pot and casserole handles



Förje stock pots and casseroles are fitted with two, heavy duty, stainless steel side handles. All handles are welded to the bodies, and items with a capacity greater than 7 litres have the added support of stainless steel rivets.

Förje Range



Stock pot

Model	Capacity (Lt)	Diameter (mm)	Height (mm)	Thickness (mm)
WSS8	8.0	240	205	0.8
WSS12	12.0	260	225	0.8
WSS16	16.0	280	260	0.8
WSS20	20.0	320	265	1.0
WSS24	24.0	340	265	1.0
WSS36	36.0	360	360	1.0
WSS50	50.0	400	400	1.0
WSS70	70.0	450	450	1.2
WSS98	98.0	500	500	1.2



Casserole - High

Model	Capacity (Lt)	Diameter (mm)	Height (mm)	Thickness (mm)
CH2	2.4	160	120	0.8
CH4	4.4	200	140	0.8
CH7	7.2	240	160	0.8
CH11	11.1	280	180	0.8



Casserole - Low

Model	Capacity (Lt)	Diameter (mm)	Height (mm)	Thickness (mm)
CL3	3.3	200	105	0.8
CL5	5.0	240	110	0.8
CL8	8.0	280	130	0.8
CL13	12.9	320	160	1.0



Saucepan - High

Model	Capacity (Lt)	Diameter (mm)	Height (mm)	Thickness (mm)
SH2	2.4	160	120	0.8
SH4	4.4	200	140	0.8
SH7	7.2	240	160	0.8



Saucepan - Low

Model	Capacity (Lt)	Diameter (mm)	Height (mm)	Thickness (mm)
SL1	1.0	140	75	0.8
SL1T*	1.0	140	75	0.8
SL2	1.9	160	95	0.8
SL3	3.3	200	105	0.8
SL5	5.0	240	110	0.8

*T indicates the interior is Excalibur® non-stick coated.



Saucepan - Conical

Model	Capacity (Lt)	Diameter (mm)	Height (mm)	Thickness (mm)
CS1	1.00	160	60	0.8
CS2	1.60	200	65	0.8
CS3	2.75	240	75	0.8



Frying pan

Model	Capacity (Lt)	Diameter (mm)	Height (mm)	Thickness (mm)
FP20	1.25	200	40	0.8
FP24	2.00	240	45	0.8
FP28	3.00	280	50	0.8
FP32	3.75	320	55	0.8
FP36	5.00	360	65	1.0
FP40	6.25	400	70	1.0



Frying pan - Excalibur® non-stick coated

Model	Capacity (Lt)	Diameter (mm)	Height (mm)	Thickness (mm)
FP20T	1.25	200	40	0.8
FP24T	2.00	240	45	0.8
FP28T	3.00	280	50	0.8
FP32T	3.75	320	55	0.8
FP36T	5.00	360	65	1.0
FP40T	6.25	400	70	1.0



Steamer

Model	Description	Thickness (mm)
ST234	Suits SL/SH/CL/CH2,3&4	0.6
ST78	Suits WSS8/CH7/SH7	0.8
ST12	Suits WSS12	0.8
ST16	Suits WSS16	0.8



Lids

Model	Diameter (mm)	Height (mm)	Thickness (mm)
L14	140	40	0.8
L16	160	50	0.8
L20	200	50	0.8
L24	240	50	0.8
L26	260	50	0.8
L28	280	50	0.8
L32	320	50	1.0
L34	340	50	1.0
L36	360	50	1.0
L40	400	50	1.0
L45	450	50	1.2
L50	500	50	1.2



Extreme Performance Range



Features

Förje XP model frying pans are manufactured using three-ply clad technology, giving them faster and greater heat absorption and a more even heat-spread over the entire pan. The three-ply cladding extends from the base to the rim of the XP range delivering extreme performance over the base as well as the sides of each model. The interior has a 'fine satin' finish for durability, with the exterior featuring a mirror finish for stunning good looks.

Heavy duty rivets



Mirror finish



Three-ply clad technology

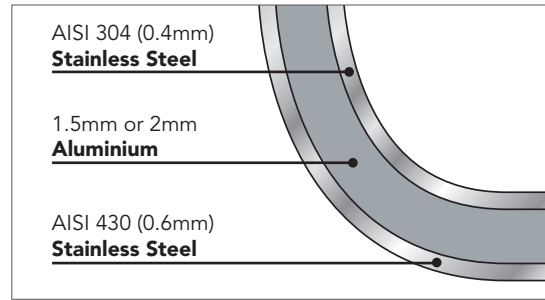

Förje Extreme Performance Range



Frying pan - Extreme Performance

Model	Capacity (Lt)	Diameter (mm)	Height (mm)	Thickness (mm)
FP26XP	2.5	260	60	2.5
FP30XP	3.5	300	60	3.0
FP32XP	4.5	320	60	3.0



Saucepan - Low - Extreme Performance

Model	Capacity (Lt)	Diameter (mm)	Height (mm)	Thickness (mm)
SL2XP	2	180	90	2.5



Casserole - Low - Extreme Performance

Model	Capacity (Lt)	Diameter (mm)	Height (mm)	Thickness (mm)
CL3XP	3	200	100	2.5



ROBAND[®]
AUSTRALIA PTY LTD

Distributed by:

Roband Australia Pty Ltd
11 Inman Road
Cromer, NSW 2099
Australia
Ph: 61 - 2 - 9971 1788
Facsimile 61 - 2 - 9971 1336
email: sales@roband.com.au

Roband New Zealand Ltd
Greenmount Drive
East Tamaki
New Zealand
Ph: 64 - 9 - 274 1355
Facsimile 64 - 9 - 274 1356
email: roband@roband.co.nz

Förje is a registered trademark of Roband Australia Pty Ltd (ACN 003 049 063)
Constant research and development may necessitate product specification changes at any time.
All products contained in this catalogue are sold subject to our terms and conditions of trade.
Images © 2009

Distributor: